



Quick Term II

Cold Shrink™ Silicone Rubber Termination (With High-K Stress Relief)

Instruction Sheet

IEEE Std. No. 48-1990

Class 1 Termination

15 kV Class

110 kV BIL

Kit Contents:

- 3 Hi-K Silicone Rubber Terminations
- 3 Mechanical Ground Strap Assemblies
- 3 Strips Sealing Mastic
(black with white release liners, bagged)
- 1 Roll of Scotch™ 13 Semi-Conducting Tape
- 1 Roll of Scotch™ 70 Silicone Rubber Tape
- 3 Packs of Silicone Grease
(clear 5cc tube with green letters)
- 1 Scotch™ Cable Preparation Kit
- 1 Instruction Sheet

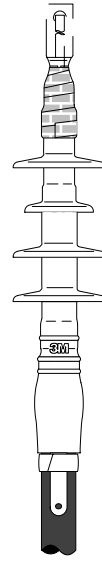



5 to 15 kV Kit Selection Chart

NOTE: Final determining factor is cable insulation diameter

Kit Number	Cable Insulation O.D. Range	Cable Jacket O.D. Range	Conductor Size Range (AWG & kcmil)				
			5 kV	8 kV 100%	8 kV 133%	15 kV 100%	15 kV 133%
5633K	0.64 – 0.90 in. (16,3 – 22,9 mm)	0.80 – 1.20 in. (20,3 – 30,5 mm)	3/0 – 300	2/0 – 250	1/0 – 4/0	2 – 3/0	4 – 1/0
5635K	0.84 – 1.33 in. (21,3 – 33,8 mm)	1.00 – 1.60 in. (25,4 – 40,6 mm)	350 – 750	300 – 750	250 – 600	3/0 – 500	2/0 – 350
5636K	1.10 – 1.65 in. (27,9 – 41,9 mm)	1.30 – 1.90 in. (33,0 – 48,3 mm)	750 – 1500	750 – 1250	600 – 1000	500 – 1000	350 – 750
5637K	1.30 – 1.95 in. (33,0 – 49,5 mm)	1.50 – 2.40 in. (38,1 – 61,0 mm)	1000 – 2000	1000 – 2000	800 – 1750	750 – 1750	600 – 1500

Table 1

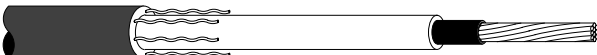
 <p style="text-align: center;">Tape Shield</p>  <p style="text-align: center;">Wire Shield</p>  <p style="text-align: center;">UniShield®</p> <p><small>UniShield® is a registered trademark of BICC Corporation</small></p>	<h2>Quick Term II</h2> <h3>Silicone Rubber Termination Kits</h3> <p>for Single Conductor Tape Shielded, Wire Shielded or UniShielded® Cables</p> <p>5633K 5636K 5635K 5637K</p>
78-8114-1266-3	
NUMBER OF PAGES: 10	SCALE: Not to scale
ISSUE DATE: 3/19/96	ISSUE: B

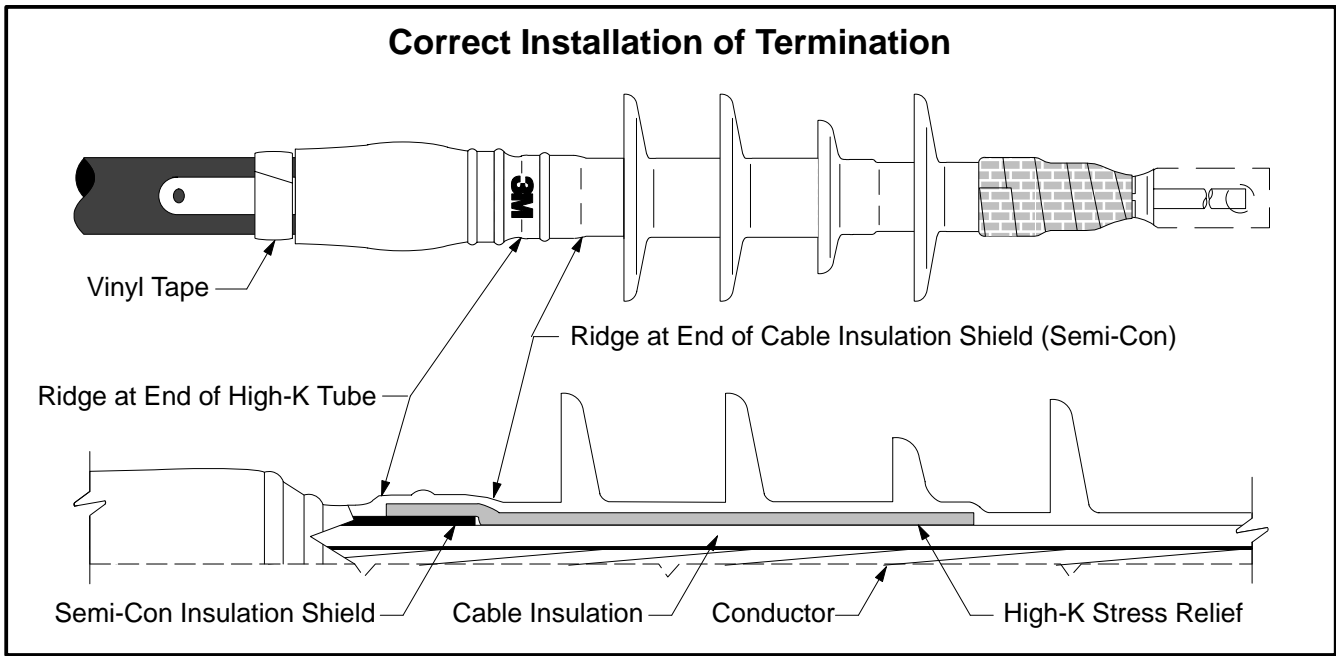

A. Prepare Cable

Dimension	Kit Number			
	5633K	5635K	5636K	5637K
[A]	9 1/2" (241 mm)		10" (254 mm)	

Table 2

1. Check to be sure cable size fits within kit range as shown in *Table 1* (cover page).
2. Prepare cable by following directions suited to specific shielding type.

NOTE: All Shield Types – After stripping back cable jacket and shield layers, clean cable insulation using one solvent pad from enclosed Scotch™ Brand Cable Preparation Kit. DO NOT ALLOW SOLVENT CONTACT WITH CABLE SHIELD SYSTEM.

If abrasive is required, use only 120 grit aluminum oxide as provided in the cable preparation kit.

Tape Shielded Cable

1. Prepare cable using dimensions shown in *Table 2* and *Figure 1* below.
(Be sure to allow for depth of lug barrel).

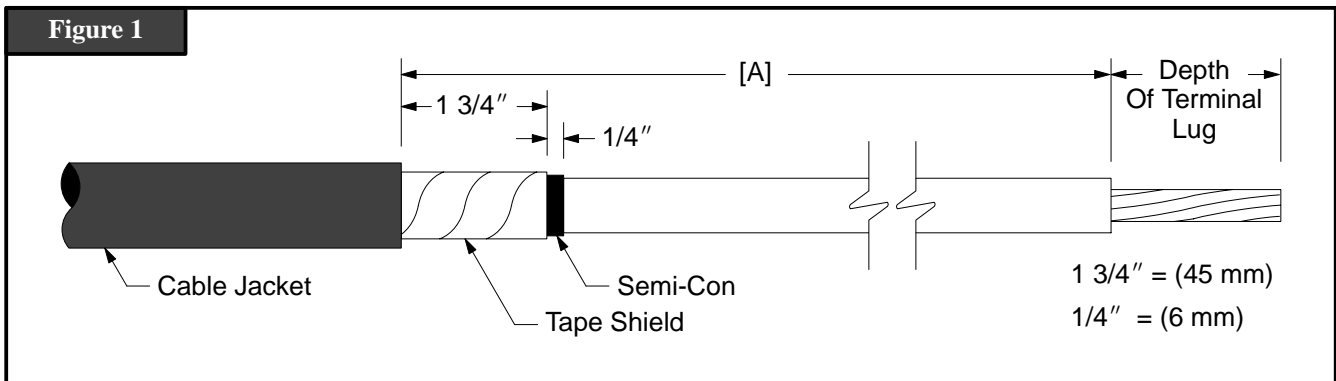

- Wrap 2 highly stretched half-lapped layers of Scotch™ 13 Semi-Conducting Tape over the tape shield and semi-con ① (Figure 2) extending 1/2" (13 mm) onto cable insulation. Start and end taping 3/4" (19 mm) onto tape shield. Provide a smooth, even leading edge over cable insulation as shown ② (Figure 2).
- Proceed to step B.

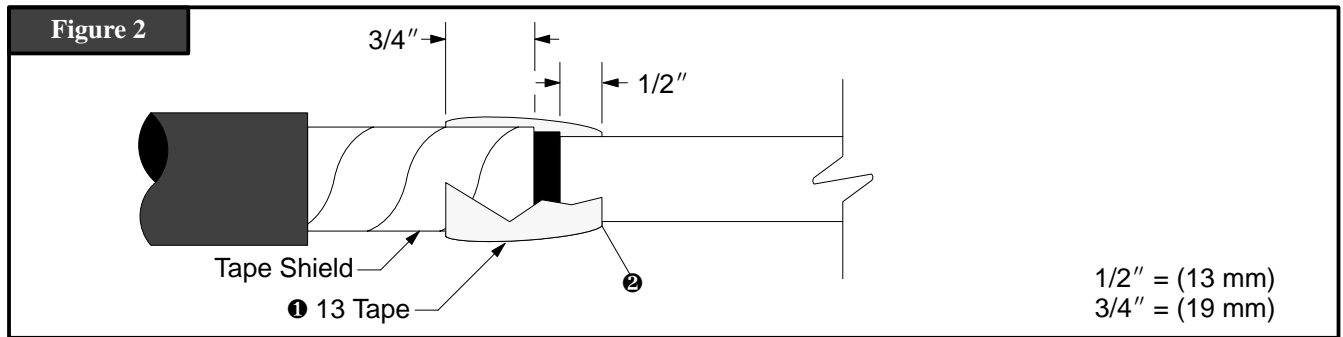

Wire Shielded Cable

- Prepare cable using dimensions shown in Table 2 and Figure 3 below.
(Be sure to allow for depth of lug barrel).

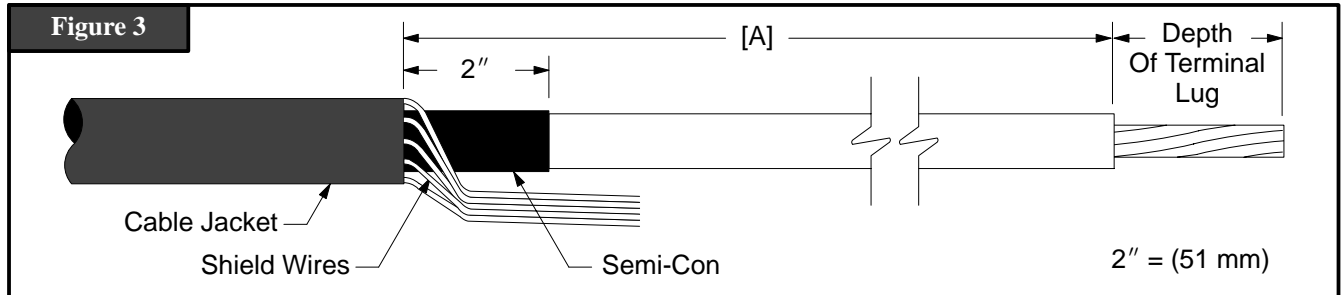

- Select one of three mastic strips, provided in kit and remove liners. Using slight tension, wrap a band of mastic around the cable jacket 1/4" (6 mm) from cut edge ① (Figure 4). Cut off excess.
- Bend drain wires back and press into applied mastic. Overwrap mastic with two layers of highly stretched vinyl tape (e.g. Scotch™ 33+ tape, not supplied) ② (Figure 4).
- Wrap 2 highly stretched half-lapped layers of Scotch™ 13 Semi-Conducting Tape over the cable semi-con ③ (Figure 4) extending 1/2" (13 mm) onto cable insulation. Start and end taping 3/4" (19 mm) onto semi-con shield. Provide a smooth, even leading edge over cable insulation as shown.
- Place a marker tape 4" (102 mm) back from the insulation-end of the 13 tape as shown ④ (Figure 4).
- Proceed to step C.

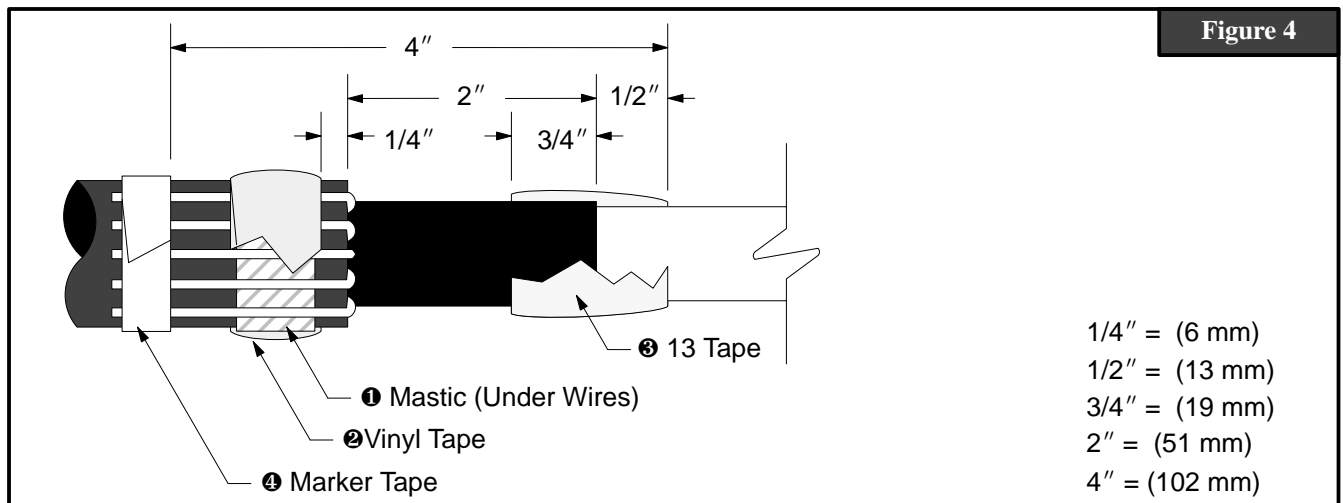

UniShield® Shielded Cable

1. Prepare cable using dimensions shown in *Table 2* and *Figure 5* below.
2. Select one of three mastic strips, provided in kit and remove liners. Using slight tension, wrap a band of mastic around the cable jacket at dimension shown ❶ (*Figure 5*).
3. Pull drain wires through semi-conductive jacket to leading edge of applied mastic band ❷ (*Figure 5*).

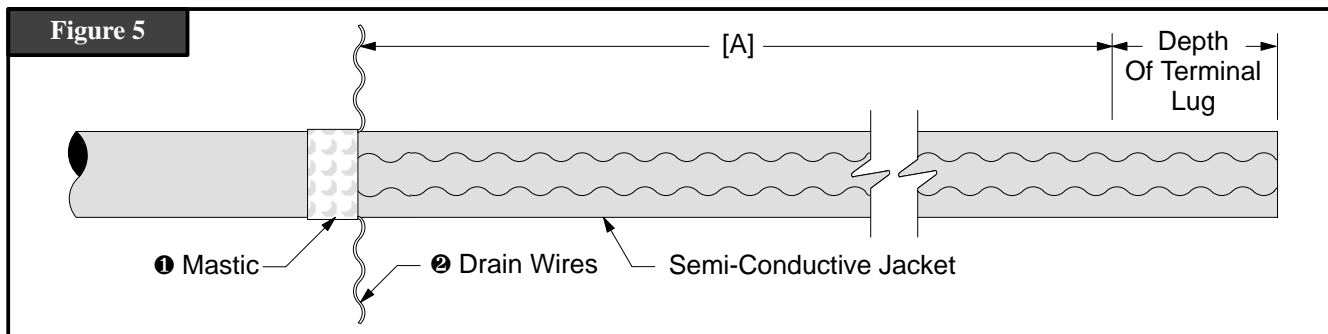

4. Bend drain wires back and press into mastic ❸ (*Figure 6*). Overwrap mastic with a highly stretched two-layer band of vinyl tape (e.g. Scotch™ 33+ tape, not supplied) ❹ (*Figure 7*).
5. Remove semi-conductive jacket leaving 1 1/2" (38 mm) exposed beyond drain wires as shown ❺ (*Figure 6*).

NOTE: To ease jacket removal, install hose clamp (not provided) as shown and ring cut 80% through jacket ❻ (*Figure 6*). Remove jacket sections by pulling against hose clamp. DO NOT BELL SEMI-CON JACKET. Remove hose clamp.

Some "UniShield®" cables feature dual-layer conductive jackets. Both layers must be removed during cable preparation.

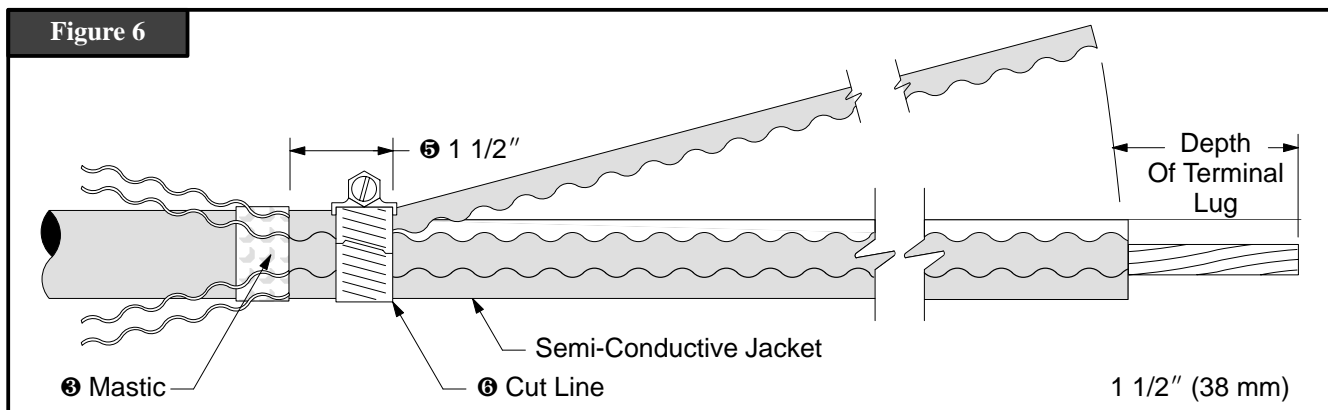

6. Wrap 2 highly stretched half-lapped layers of Scotch™ 13 Semi-Conducting Tape over end of cable semi-conductive jacket extending 1" (25 mm) onto cable insulation. Start and end taping at drain wires. Provide a smooth, even leading edge over cable insulation as shown ❼ (*Figure 7*).
7. Place a marker tape 4" (102 mm) back from the insulation end of the 13 Tape ❽ (*Figure 7*).
8. Proceed to Step C.

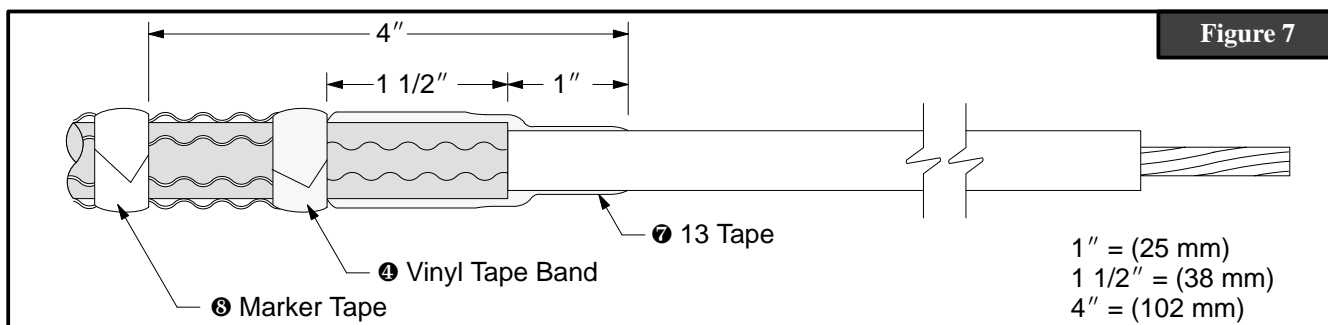

B. Install Ground Strap (Tape Shield Cables Only)

1. Unwrap 1" to 2" (25 mm to 50 mm) of coiled flat strap. Position ground strap assembly with tail extending along cable jacket and coiled end facing down and away from you, over metallic shielding ❶ (Figure 8). Hold the ground strap tail in place with thumb ❷ (Figure 8) while wrapping the coiled end, counter-clockwise, around the cable metallic shield ❶ (Figure 8). Cinch (tighten), the attached constant-force spring after final wrap.

NOTE: *Wrapped portion of ground strap must contact cable metallic shield only. Adjust location if needed.*

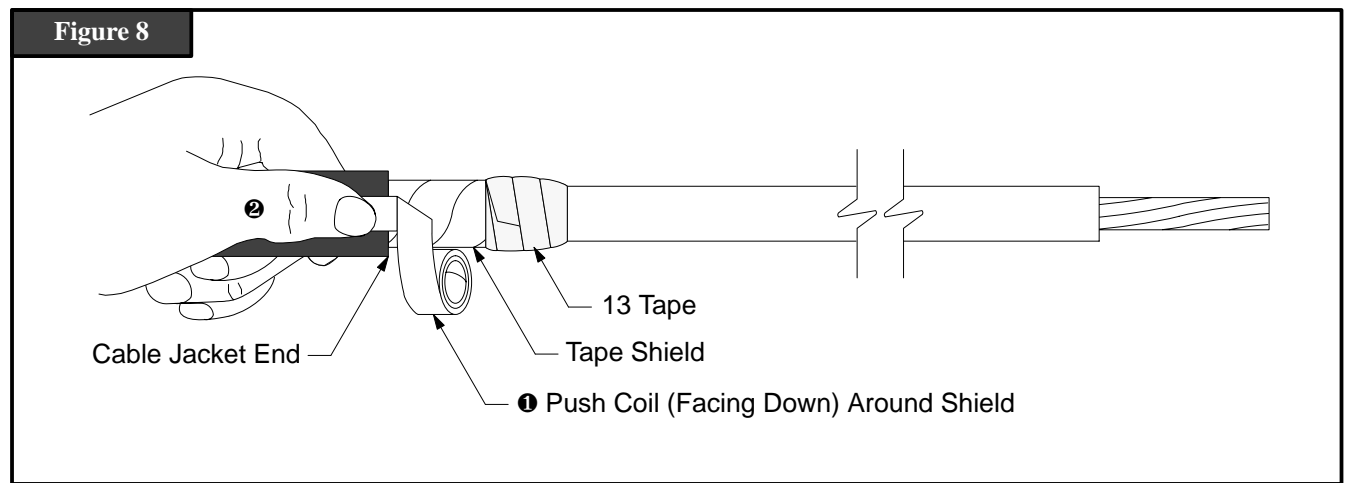

2. Seal ground strap
 - a. Select one of three mastic strips provided in kit. Cut 2 pieces 1 1/2" (38 mm) long and remove liners.
 - b. Place 1 piece under grounding strap 1/4" (6 mm) from cable jacket cut edge. Push strap into mastic and place the second piece over ground strap ❸ (Figure 9).

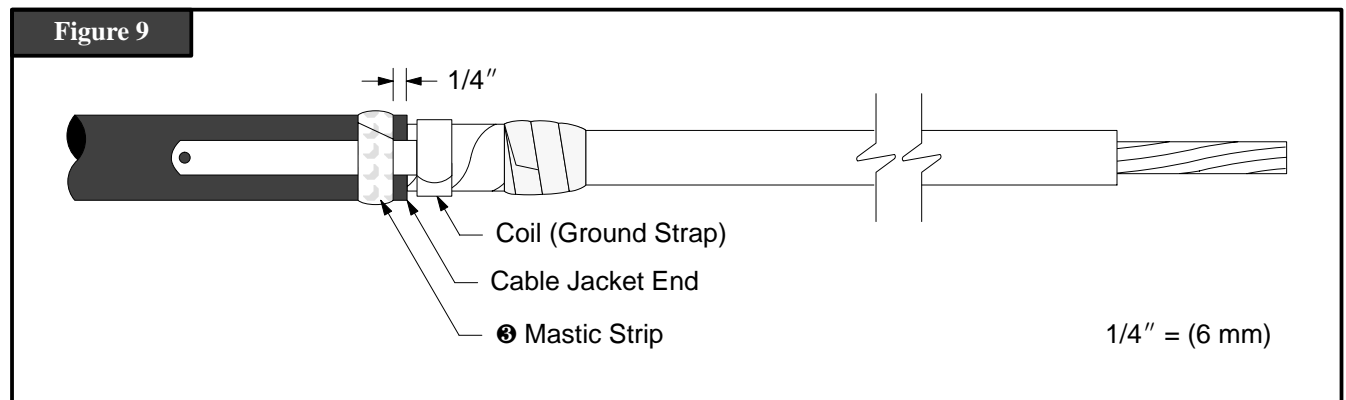

3. Wrap 1 half-lapped layer of highly stretched vinyl tape (e.g. Scotch™ Super 33+ Tape, not supplied in kit) over applied mastic and ground strap coil ❹ (Figure 10). **Do not cover previously applied 13 tape.**
4. Place a marker tape 4" (102 mm) back from the insulation end of the 13 Tape, as shown ❺ (Figure 10).

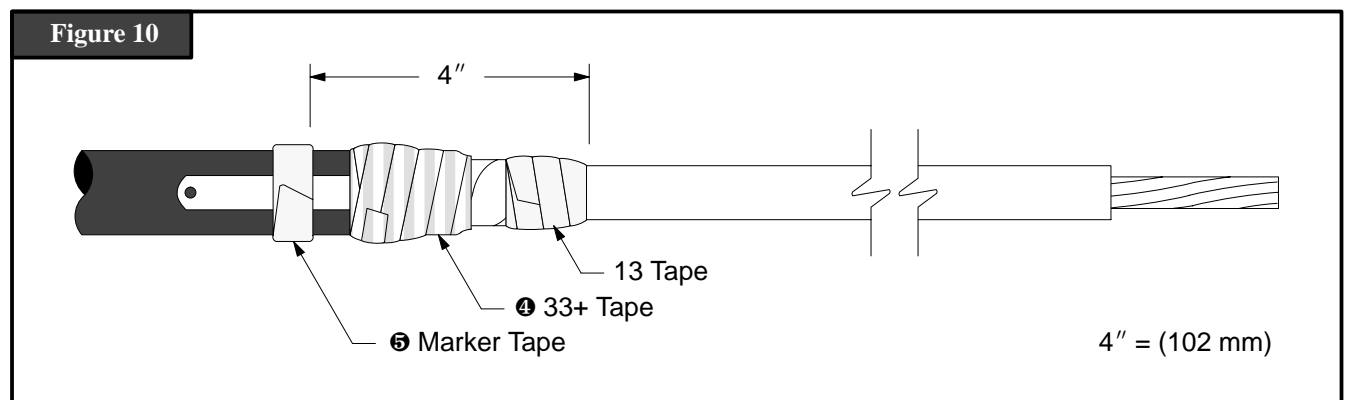

C. Install Termination (All Shield Types)

1. Cover the edge of the 13 Tape with a liberal coating of silicone grease ❶ (Figure 11).

NOTE: On this product the silicone grease does not serve as a lubricant. It must be used to fill the step at the 13 Tape leading edge.

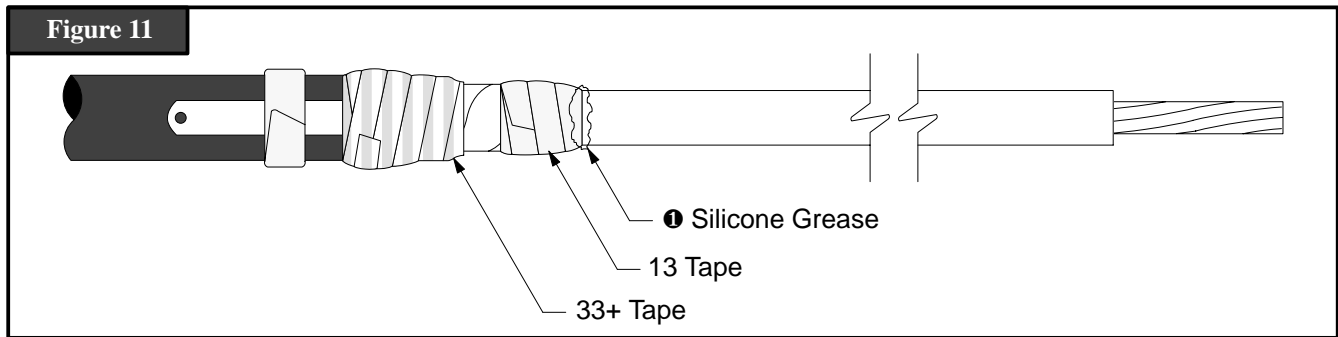

2. Silicone grease may also be applied over the ground strap seal to aid in core removal and initial insulator alignment.
3. Slide the termination body onto the cable, aligning the base with previously applied marker tape (all shield types) ❷ (Figure 12).
4. Remove termination core unwinding counter-clockwise ❸ (Figure 12) starting with the loose end. Make sure the termination body is butted up to the edge of the marker tape ❷ (Figure 12).

TIP: An occasional tug of the core strand while unwinding will aid in core removal.

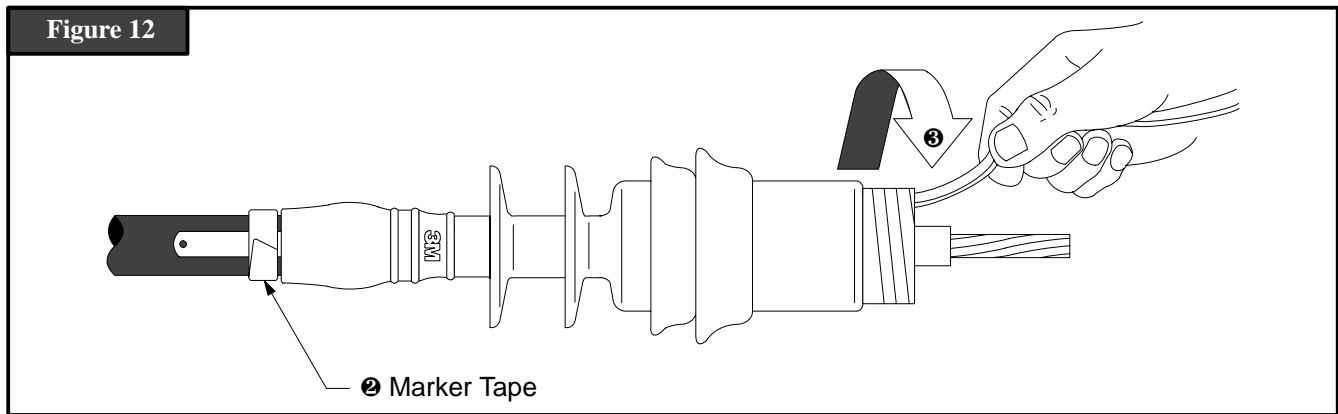

D. Install Terminal Lug

1. Install terminal lug per manufacturer's direction. See page 8 or 9 if 3M lugs are used.
2. Wrap 4 half-lapped layers of Scotch™ 70 Silicone Rubber Tape over the lug and onto the insulator for 1" (25 mm) ❶ (Figure 13). Start and end taping on the lug barrel.

TAPING HINT: Apply Scotch™ 70 Silicone Rubber Tape with minimum tension (just enough to avoid folds or wrinkles).

3. If lug is not used, solder block conductor and wrap 4 half-lapped layers of 70 Tape from the solder block to 1" (25 mm) onto the insulator using "Taping Hint".

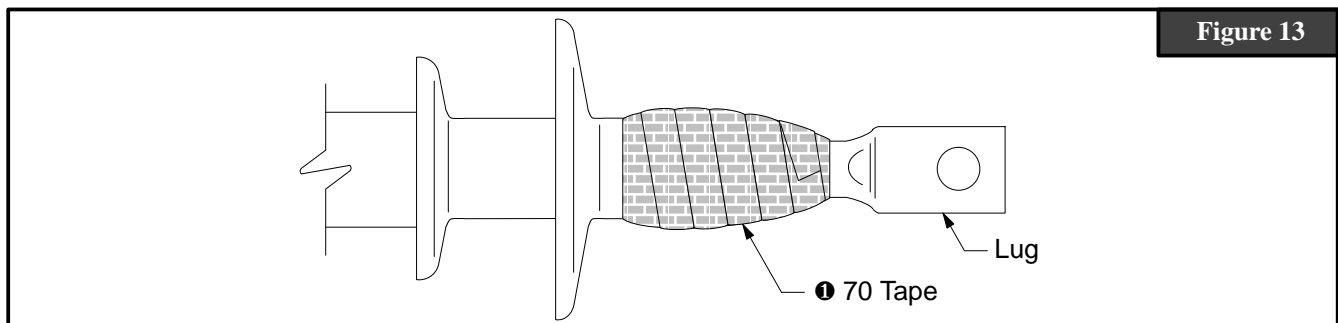

E. Grounding

1. If cable is to be grounded at termination, connect as shown. Use **braid or wire appropriately sized for system requirements**.
Termination Ground Strap ❶ (*Figure 14*) is copper conductor equivalent of 9 AWG Solid.
2. Scotch™ number 25 grounding braid (number 6 AWG solid copper equivalent) is suitable for general grounding requirements.

Figure 14

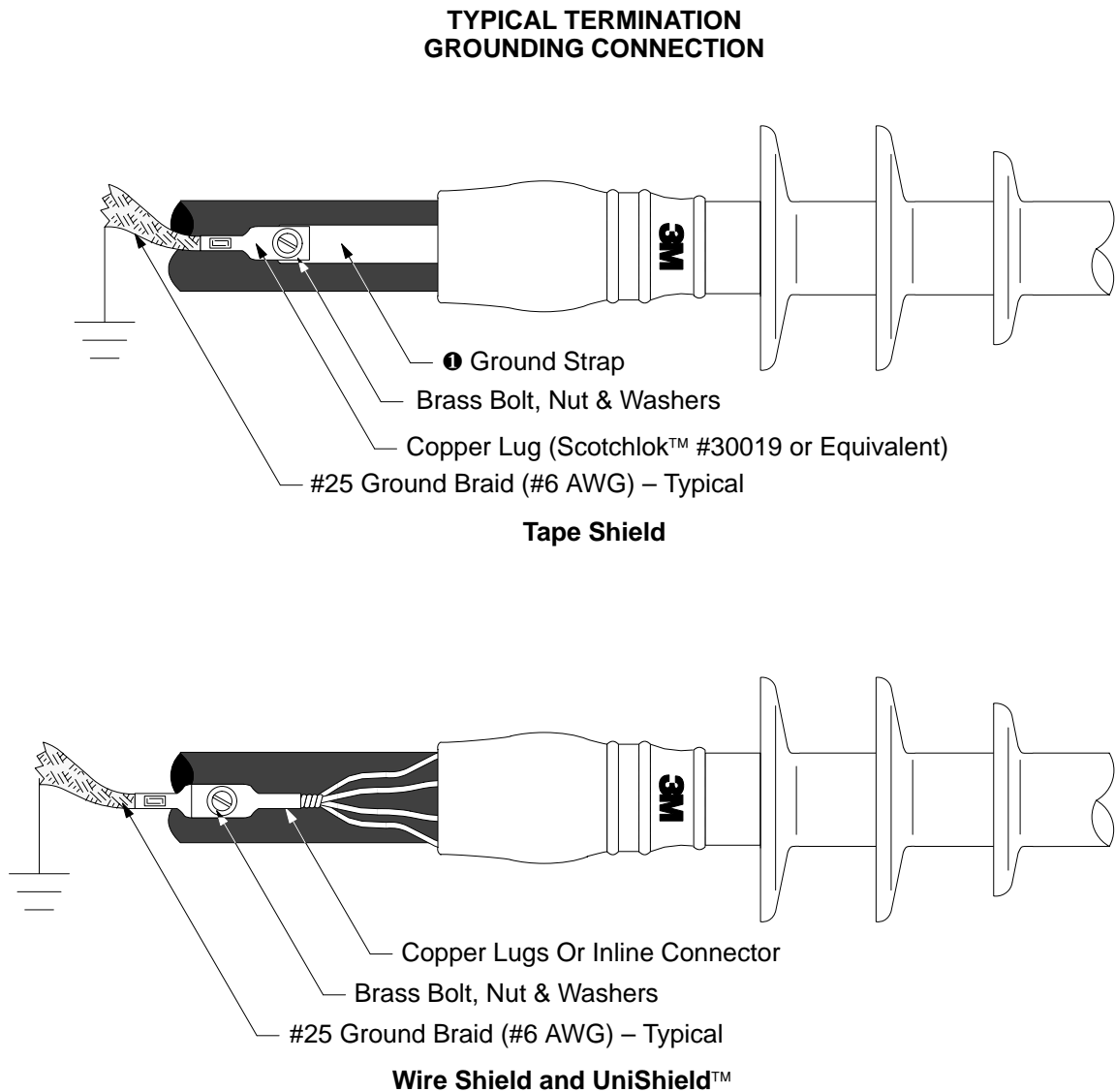

Tooling Index

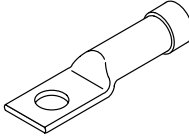
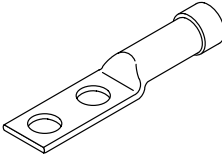
Lug and Crimping Information for Scotchlok™ Copper/Aluminum Lugs															
40016 thru 40079 One hole								40132 thru 40178 Two hole							
															
Cable Size AWG/ kcmil	Stud Size (in.)	Scotchlok™ Lug Number	CRIMPING TOOL-DIE SETS (NUMBER OF CRIMPS)												
			Burdny Corporation					Thomas & Betts Corporation				Square D Co. Anderson Div.		ITT Blackburn Co.	Kearny Nat'l Div.
			MD6	MY29	Y34A	Y35, Y39, Y45*, Y46*	Y1000*	TBM 5	TBM 8	TBM 12	TBM 15	VC6-3** VC6-FT**	VC8C**	OD58	TYPE O
6	5/16	40016	W161(1)	6AWG(1)	A6CAB(1)	U6CABT(1)	(1)	Grey(1)	Grey(1)	—	29(1)	(1)	—	BY19(3)	J(3)
4	5/16	40020	W162(3)	4AWG(1)	A4CAB(1)	U4CABT(1)	(1)	Green(2)	Green(2)	—	37(1)	(1)	—	BY53(3)	P(3)
2	3/8 1/2	40024 40025	W163(3) W163(3)	2AWG(1) 2AWG(1)	A2CAB(1) A2CAB(1)	U2CABT(1) U2CABT(1)	(1) (1)	Pink(2) Pink(2)	Pink(2) Pink(2)	—	42H(2) 42H(2)	(1) (1)	—	BY23(3) BY23(3)	1/2(3) 1/2(3)
1	3/8 1/2	40028 40029	W163(3) W163(3)	1AWG(1) 1AWG(1)	A1CAR(1) A1CAR(1)	U1CART(1) U1CART(1)	(1) (1)	Gold(2) Gold(2)	Gold(2) Gold(2)	—	45(1) 45(1)	(1) (1)	—	BY23(3) BY23(3)	1/2(3) 1/2(3)
1/0	3/8 1/2 3/8	40032 40033 40132	W241(3) W241(3) W241(3)	1/0(1) 1/0(1) 1/0(1)	A25AR(1) A25AR(1) A25AR(1)	U25ART(1) U25ART(1) U25ART(1)	(1) (1) (1)	Tan(2) Tan(2) Tan(2)	Tan(2) Tan(2) Tan(2)	—	50(1) 50(1) 50(1)	(1) (1) (1)	—	BY25(3) BY25(3) BY25(3)	5/8-1(3) 5/8-1(3) 5/8-1(3)
2/0	1/2 1/2	40037 40137	BG(4) BG(4)	2/0(1) 2/0(1)	A26AR(2) A26AR(2)	U26ART(2) U26ART(2)	(1) (1)	Olive(2) Olive(2)	Olive(2) Olive(2)	—	54H(2) 54H(2)	(2) (2)	—	BY31C(3) BY31C(3)	5/8-1(3) 5/8-1(3)
3/0	1/2 1/2	40041 40141	W166(4) W166(4)	3/0(1) 3/0(1)	A27AR(2) A27AR(2)	U27ART(2) U27ART(2)	(1) (1)	Ruby(2) Ruby(2)	Ruby(2) Ruby(2)	—	60(2) 60(2)	(2) (2)	—	—	737(3) 737(3)
4/0	1/2 5/8 1/2	40045 40046 40145	W660(4) W660(4) W660(4)	4/0 (2) 4/0 (2) 4/0 (2)	A28AR(2) A28AR(2) A28AR(2)	U28ART(2) U28ART(2) U28ART(2)	(1) (1) (1)	—	White(4) White(4) White(4)	—	66(4) 66(4) 66(4)	(2) (2) (2)	—	BY35C(4) BY35C(4) BY35C(4)	840(4) 840(4) 840(4)
250	1/2 5/8 1/2	40049 40050 40149	W249(3) W249(3) W249(3)	—	A29AR(2) A29AR(2) A29AR(2)	U29ART(2) U29ART(2) U29ART(2)	(1) (1) (1)	—	—	71H(4) 71H(4) 71H(4)	71H(2) 71H(2) 71H(2)	(3) (3) (3)	—	—	—
300	1/2 1/2	40053 40153	—	—	A30AR(2) A30AR(2)	U30ART(2) U30ART(2)	(1) (1)	—	—	76H(4) 76H(4)	76H(2) 76H(2)	(3) (3)	—	—	—
350	1/2 5/8 1/2	40056 40057 40156	—	—	—	U31ART(2) U31ART(2) U31ART(2)	(1) (1) (1)	—	—	87H(4) 87H(4) 87H(4)	87H(3) 87H(3) 87H(3)	(3) (3) (3)	—	—	—
400	1/2	40160	—	—	—	U32ART(4)	(1)	—	—	94H(4)	94H(4)	—	(2)	—	—
500	5/8 1/2	40067 40166	—	—	—	U34ART(4) U34ART(4)	(1) (1)	—	—	106H(4) 106H(4)	106H(3) 106H(3)	—	(2) (2)	—	—
600	1/2	40170	—	—	—	U36ART(4)	(1)	—	—	—	115H(3)	—	(3)	—	—
750	5/8 1/2	40073 40172	—	—	—	U39ART(4) U39ART(4)	(1) (1)	—	—	—	125H(5) 125H(5)	—	(3) (3)	—	—
1000	5/8 1/2	40079 40178	—	—	—	S44ART(4) S44ART(4)	(1) (1)	—	—	—	140H(4) 140H(4)	—	(3) (3)	—	—

* Y45 and Y46 accept all Y35 dies ("U" series). For Y45 use PT6515 adapter. For Y46 use PUADP adapter.

** Anderson VC6-3, VC6-FT, VC8C and Burndy Y1000 require no die set.

Tooling Index

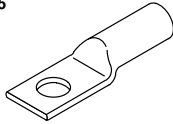
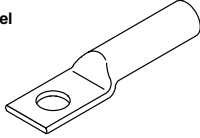
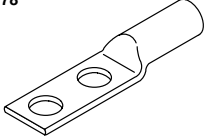
Lug and Crimping Information for Scotchlok™ Copper Lugs										
30014 thru 30045 One hole 			31036 thru 31068 One hole — long barrel 				31145 thru 31178 Two hole 			
Cable Size AWG/ kcmil	Stud Size (in.)	Scotchlok™ Copper Lug Number	CRIMPING TOOL-DIE SETS (NUMBER OF CRIMPS)							
			Burdny Corporation				Thomas & Betts Corporation			Square D Co. An- derson Div.
			MD6	MY29	Y34A	Y35, Y39, Y45*, Y46*	TBM 5	TBM 8	TBM 15	VC6-3, VC6-FT**
6	10 1/4 5/16	30014 30015 30016	—	6AWG(1)	—	U5CRT(1)	Blue(1)	Blue(1)	—	Universal(1)
4	10 1/4 3/8	30018 30019 30021	W161(1)	4AWG(1)	A4CR(1)	U4CRT(1)	Grey(1)	Grey(1)	—	Universal(1)
2	1/4 5/16 3/8	30022 30023 30024	W162(2)	2AWG(1)	A2CR(1)	U2CRT(2)	Brown(1)	Brown(1)	33(1)	Universal(2)
1	5/16 3/8	30027 30028	—	1AWG(1)	A1CR(1)	U1CRT(2)	Green(1)	Green(1)	37(1)	Universal(2)
1/0	5/16 3/8	30031 30032	W163(2)	1/0(1)	A25R(1)	U25RT(1)	Pink(2)	Pink(2)	42H(2)	Universal(1)
2/0	3/8 3/8	30036 31036	W241(2) W241(3)	2/0(1) 2/0(2)	A26R(1) A26R(2)	U26RT(2) U26RT(3)	Black(2) Black(3)	Black(2) Black(3)	45(1) 45(2)	Universal(1) Universal(2)
3/0	1/2 1/2	30041 31041	W243(2) W243(3)	3/0(1) 3/0(2)	A27R(1) A27R(2)	U27RT(2) U27RT(3)	Orange(2) Orange(3)	Orange(2) Orange(3)	50(1) 50(2)	Universal(2) Universal(3)
4/0	1/2 1/2 1/2	30045 31045 31145	BG(3) BG(4) BG(4)	4/0(1) 4/0(2) 4/0(2)	A28R(2)	U28RT(2) U28RT(3) U28RT(3)	Purple(2) Purple(3) Purple(3)	Purple(2) Purple(3) Purple(3)	54H(2) 54H(3) 54H(3)	Universal(2) Universal(3) Universal(3)
250	1/2 1/2	31049 31149	W166(4)	250(2)	A29R(2)	U29RT(3)	Yellow(2)	Yellow(2)	62(2)	Universal(2)
300	1/2 1/2	31053 31153	—	—	A30R(2)	U30RT(3)	—	White(3)	66(3)	Universal(3)
350	1/2 1/2	31056 31156	—	—	A31R(2)	U31RT(3)	—	Red(4)	71H(4)	—
400	1/2 1/2	31060 31160	—	—	A32R(2)	U32RT(3)	—	Blue(4)	76H(4)	—
500	1/2 5/8 1/2	31066 31067 31166	—	—	A34R(2)	U34RT(3)	—	Brown(4)	87H(4)	—
600	1/2 1/2	31068 31168	—	—	—	U36RT(3)	—	Green(4)	94H(4)	—
750	1/2	31172	—	—	—	Y39, Y45, Y46 U39RT(5)	—	—	106H(4)	—
1000	1/2	31178	—	—	—	Y45: S44RT(6) Y46: P44RT(6)	—	—	125H(4)	—

* Y45 and Y46 accept all Y35 dies ("U" series). For Y45 use PT6515 adapter. For Y46 use PUADP adapter.

** Anderson VC6-3, VC6-FT, VC8C and Burndy Y1000 require no die set.

Tooling Index

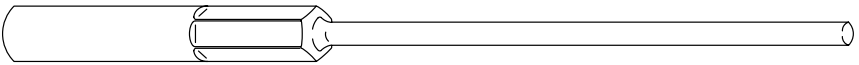
Crimping Information for 3M Stem Connectors Copper/Aluminum						
CRIMPING TABLE FOR 3M STEM TYPE CONNECTOR						
Conductor Size	3M Connector Number	Recommended Crimping Tools				
		Manufacturer	Mech. Tool	Die (No. Crimps)	Hydraulic	Die (No. Crimps)
2 Solid 1, 2 1/0	SC0020 SC0001 SC0010	Burndy	MD6	BG(4), W243(4)	Y35, Y39, Y45**	U25ART(2), U243(2)
		Kearny	0-51, 0-52	5/8-1 (4)	12, 20, 40, Ton	5/8-1(4)
		T & B	TBM 8	Olive(2)	TBM 15	50(2)*
		Anderson	—	—	VC6	Universal(2)
2/0 3/0 4/0	SC0020 SC0030 SC0040	Burndy	MD6	W669(0) 840(5)*	Y35, Y39, Y45**	U28ART(2)
		Kearny	0-51, 0-52	840(5)*	WH-1, WH-2	840(2)
		T & B	TBM 8	White(4)	TBM 15	66(3)
		Anderson	-	—	VC6	Universal(2)

* Y45 and Y46 accept all Y35 dies ("U" series). For Y45 use PT6515 adapter. For Y46 use PUADP adapter.
 ** Anderson VC6-3, VC6-FT, VC8C and Burndy Y1000 require no die set.

'3M', 'Cold Shrink', 'Scotch' and 'Scotchlok' are trademarks of 3M.
 UniShield® is a registered trademark of BICC Cables.

Important Notice to Purchaser:

All statements, technical information and recommendations related to the Seller's products are based on information believed to be reliable, but the accuracy or completeness thereof is not guaranteed. Before utilizing the product, the user should determine the suitability of the product for its intended use. The user assumes all risks and liability whatsoever in connection with such use.

Any statements or recommendations of the Seller which are not contained in the Seller's current publications shall have no force or effect unless contained in an agreement signed by an authorized officer of the Seller. The statements contained herein are made in lieu of all warranties expressed or implied, including but not limited to the implied warranties of merchantability and fitness for a particular purpose which warranties are hereby expressly disclaimed.

SELLER SHALL NOT BE LIABLE TO THE USER OR ANY OTHER PERSON UNDER ANY LEGAL THEORY, INCLUDING BUT NOT LIMITED TO NEGLIGENCE OR STRICT LIABILITY, FOR ANY INJURY OR FOR ANY DIRECT OR CONSEQUENTIAL DAMAGES SUSTAINED OR INCURRED BY REASON OF THE USE OF ANY OF THE SELLER'S PRODUCTS.



Electrical Products Division
 6801 River Place Blvd.
 Austin, TX 78726-9000



Recycled paper
 40% pre-consumer
 10% post-consumer

Litho in USA
 © 1997 3M
 78-8114-1266-3 (B)