

Reversing contactor Size 3 1/2 Three phase full voltage Contactor
 amp rating 115Amp 3 110-120/220-240VAC 60HZ coil Non-
 combination type Enclosure NEMA type (open) No enclosure



Figure similar

General technical data	
Weight [lb]	13 lb
Height x Width x Depth [in]	11.44 × 12.75 × 5.65 in
Protection against electrical shock	Not finger-safe
Installation altitude [ft] at height above sea level maximum	6560 ft
Ambient temperature [°F] during storage	-22 ... +149 °F
Ambient temperature [°F] during operation	-4 ... +104 °F
Ambient temperature during storage	-30 ... +65 °C
Ambient temperature during operation	-20 ... +40 °C
Country of origin	Mexico

Horsepower ratings	
Yielded mechanical performance [hp] for three-phase AC motor	
<ul style="list-style-type: none"> at 200/208 V rated value 	30 hp
<ul style="list-style-type: none"> at 220/230 V rated value 	40 hp
<ul style="list-style-type: none"> at 460/480 V rated value 	75 hp

- at 575/600 V rated value

75 hp

Contactors

Number of NO contacts for main contacts	3
Operating voltage for main current circuit at AC at 60 Hz maximum	600 V
Operating current at AC at 600 V rated value	115 A
Mechanical service life (switching cycles) of the main contacts typical	5000000

Auxiliary contact

Number of NC contacts at contactor for auxiliary contacts	2
Number of NO contacts at contactor for auxiliary contacts	2
Number of total auxiliary contacts maximum	7
Contact rating of auxiliary contacts of contactor according to UL	10A@600VAC (A600), 5A@600VDC (P600)

Coil

Type of voltage of the control supply voltage	AC
Control supply voltage	
<ul style="list-style-type: none"> • at DC rated value 	0 ... 0 V
<ul style="list-style-type: none"> • at AC at 60 Hz rated value 	110 ... 240 V
<ul style="list-style-type: none"> • at AC at 50 Hz rated value 	0 ... 0 V
Holding power at AC minimum	14 W
Apparent pick-up power of magnet coil at AC	310 V·A
Apparent holding power of magnet coil at AC	26 V·A
Operating range factor control supply voltage rated value of magnet coil	0.85 ... 1.1
Percental drop-out voltage of magnet coil related to the input voltage	50 %
Switch-on delay time	26 ... 41 ms
Off-delay time	14 ... 19 ms

Enclosure

Degree of protection NEMA rating of the enclosure	Open device (no enclosure)
Design of the housing	NA

Mounting/wiring

(mounting position)	Vertical
(mounting type)	Surface mounting and installation
Type of electrical connection for supply voltage line-side	Box lug
Tightening torque [lbf·in] for supply	120 ... 120 lbf·in
Type of connectable conductor cross-sections at line-side at AWG conductors single or multi-stranded	1x (14 ... 2/0 AWG)

Temperature of the conductor for supply maximum permissible	75 °C
Material of the conductor for supply	AL or CU
Type of electrical connection for load-side outgoing feeder	Box lug
Tightening torque [lbf·in] for load-side outgoing feeder	120 ... 120 lbf·in
Type of connectable conductor cross-sections at AWG conductors for load-side outgoing feeder single or multi-stranded	1x (14 ... 2/0 AWG)
Temperature of the conductor for load-side outgoing feeder maximum permissible	75 °C
Material of the conductor for load-side outgoing feeder	AL or CU
Type of electrical connection of magnet coil	Screw-type terminals
Tightening torque [lbf·in] at magnet coil	5 ... 12 lbf·in
Type of connectable conductor cross-sections of magnet coil at AWG conductors single or multi-stranded	2x (16 ... 12 AWG)
Temperature of the conductor at magnet coil maximum permissible	75 °C
Material of the conductor at magnet coil	CU
Type of electrical connection at contactor for auxiliary contacts	Screw-type terminals
Tightening torque [lbf·in] at contactor for auxiliary contacts	10 ... 15 lbf·in
Type of connectable conductor cross-sections at contactor at AWG conductors for auxiliary contacts single or multi-stranded	1x (12 AWG), 2x (16 ... 14 AWG), 2x (18 ... 16 AWG)
Temperature of the conductor at contactor for auxiliary contacts maximum permissible	75 °C
Material of the conductor at contactor for auxiliary contacts	CU

Short-circuit current rating

Design of the fuse link for short-circuit protection of the main circuit required	10kA@600V (Class H or K); 100kA@600V (Class R or J)
Design of the short-circuit trip	Thermal magnetic circuit breaker
Maximum short-circuit current breaking capacity (Icu) <ul style="list-style-type: none"> • at 240 V • at 480 V • at 600 V 	14 A 10 A 10 A

Further information

Industrial Controls - Product Overview (Catalogs, Brochures,...)

www.usa.siemens.com/iccatalog

Industry Mall (Online ordering system)

<https://mall.industry.siemens.com/mall/en/us/Catalog/product?mlfb=US2:43IP32AA>

Service&Support (Manuals, Certificates, Characteristics, FAQs,...)

<https://support.industry.siemens.com/cs/US/en/ps/US2:43IP32AA>

Image database (product images, 2D dimension drawings, 3D models, device circuit diagrams, EPLAN macros, ...)

http://www.automation.siemens.com/bilddb/cax_de.aspx?mlfb=US2:43IP32AA&lang=en

Certificates/approvals

<https://support.industry.siemens.com/cs/US/en/ps/US2:43IP32AA/certificate>

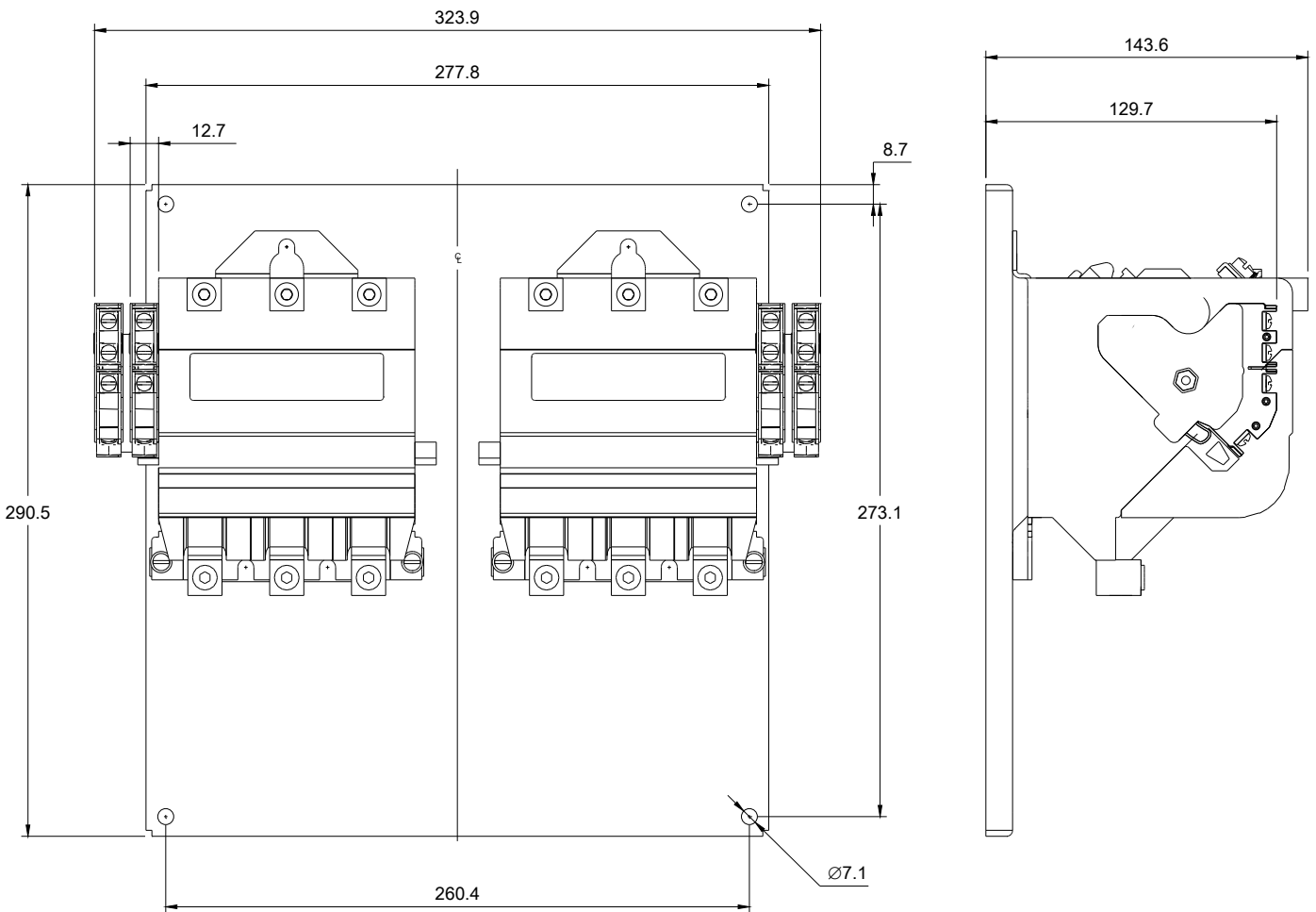

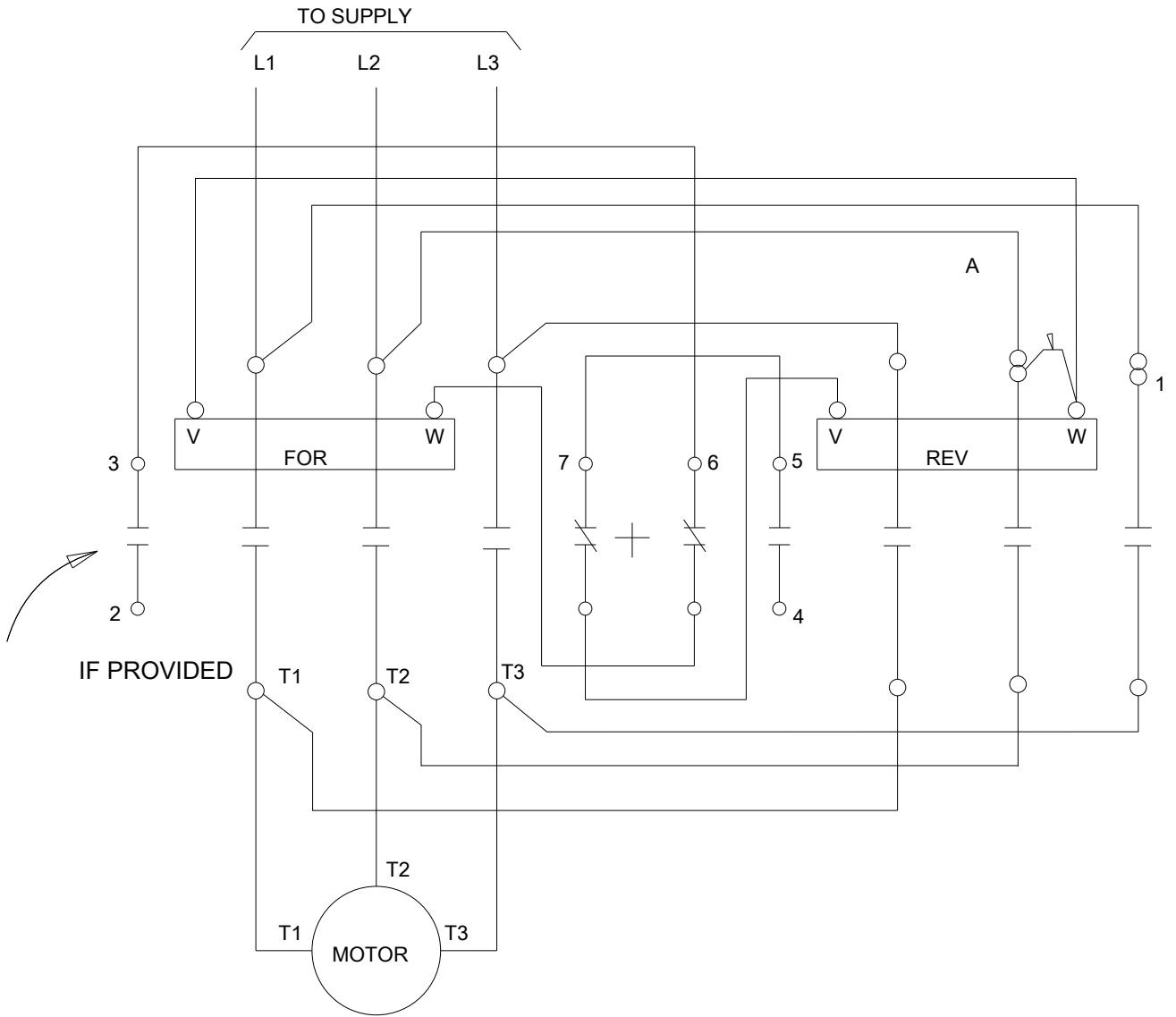

D29325001

last modified:

05/08/2019