

BETA Switching Switches and Light Indicators









7/2	Product overview
7/3	5TE8 control switches
7/7	5TE4 pushbuttons
7/12	5TE5 light indicators
7/15	5TE8 ON/OFF switches
7/22	5TE9 busbars
7/24	5TE1 switch disconnectors

BETA Switching

Switches and Light Indicators

Product overview

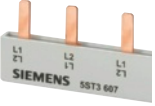
Overview

Devices	Page	Field of application	Standards	Used in		
				Non-residential buildings	Residential buildings	Industry
 <p>5TE8 control switches</p>	7/3	For the switching of lighting and other electrical devices up to 20 A. For use in control cabinets for the logical linking of functions.	IEC/EN 60947-3, (VDE 0660-107); IEC/EN 60669-1, (VDE 0632-1); GB14048.3-2002 CCC	✓	✓	✓
 <p>5TE4 pushbuttons</p>	7/7	To be used as pushbuttons in control systems, e.g. to switch on seal-in circuits or as pushbuttons with maintained-contact function for manual use, as control switches or for the switching of loads up to 20 A.	IEC/EN 60947-3, (VDE 0660-07); IEC/EN 60669-1, (VDE 0632-1); GB14048.3-2002 CCC	✓	--	✓
 <p>5TE5 light indicators</p>	7/12	Light indicators for signaling switching states or faults in systems.	DIN VDE 0710-1	✓	--	✓
 <p>5TE8 ON/OFF switches</p>	7/15	For the switching of lighting, motors and other electrical devices from 20 to 125 A.	16 A ... 25 A and 40 A ... 100 A: IEC/EN 60947-3, (VDE 0660-107); IEC/EN 60669-1, (VDE 0632-1) 32 A and 125 A: IEC/EN 60947-3, (VDE 0660-107); GB14048.3-2002 CCC	✓	✓	✓
 <p>5TE9 busbars</p>	7/22	For fast and safe connection	IEC/EN 60439-1, (VDE 0660-500)	✓	--	✓
 <p>5TE1 switch disconnectors</p>	7/24	For the switching of lighting, motors and other electrical devices or for switching system components from 100 to 200 A.	IEC/EN 60947-3; KEMA certified UL 508	✓	--	✓

Overview

Two-way switches are used in control cabinets and distribution boards for switching small loads on/off or over.

Group switches with center position permit the positions open/stop/closed, for example to control anti-clockwise rotation - Off - clockwise rotation.

Control switches in a range of contact versions have an integral control lamp for the ON setting.

The auxiliary switch (AS) signals the contact position of the switch. It has the same design as the auxiliary switch used for the miniature circuit breakers (see Chapter "Miniature Circuit Breakers").

Benefits

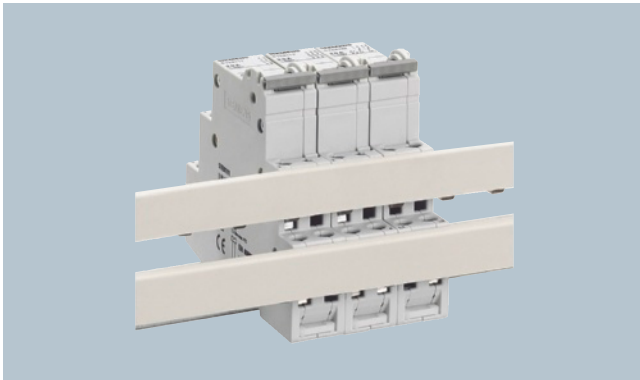

- The control switches can be bus-mounted with each other or with 5TE4 8 pushbuttons, 5TE5 8 light indicators or 5TT4 1 remote control switches and 5TT4 2 switching relays. This saves time and space.
- For busbars, see page [see page 7/22 ff.](#)

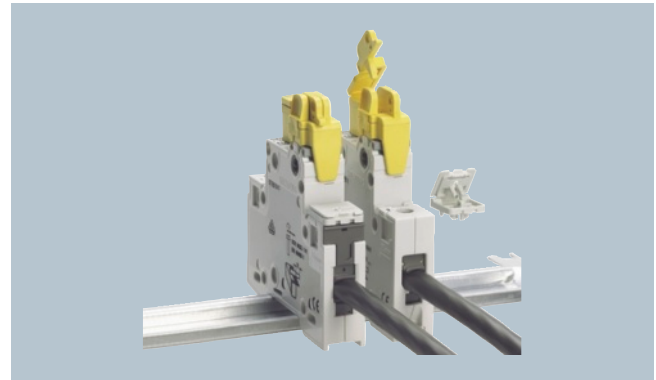

- The handle locking device prevents undesired manual on and off switching. This increases safe operation.
- The handle locking device is a universal accessory for all switches and miniature circuit breakers. This simplifies logistics.

Technical specifications





			5TE8 1
Standards			IEC/EN 60947-3 (VDE 0660-107); IEC/EN 60669-1 (VDE 0632-1) EN 60669
Approved acc. to			
Rated operational current I_e	Per conducting path	A	20
Rated operational voltage U_e	1-pole	V AC	230
	Multipole	V AC	400
Rated power dissipation P_v	Contact per pole	VA	0.7
Thermal rated current I_{the}		A	20
Rated breaking capacity	At p.f. = 0.65	A	60
Rated making capacity	At p.f. = 0.65	A	60
Short-circuit strength In conjunction with fuse of the same rated operational current	EN 60269 gL/gG	kA	10
Rated impulse withstand voltage U_{imp}		kV	> 5
Clearances	Open contacts	mm	2 × > 2
	Between the poles	mm	> 7
Creepage distances		mm	> 7
Mechanical service life	Switching cycles		25000
Electrical service life	Switching cycles		10000
Minimum contact load		V; mA	10; 300
Rated short-time currents Per conducting path at p.f. = 0.7	Up to 0.2 s	A	650
	Up to 0.5 s	A	400
	Up to 1 s	A	290
	Up to 3 s	A	170
(The respective rated surge current can be calculated by multiplying by a factor of 1.5).			
Terminals	± screw (Pozidriv)		1
Max. tightening torque		Nm	1.2
Conductor cross-sections	Rigid	mm ²	1.5 ... 6
	Flexible, with end sleeve	mm ²	1 ... 6
Permissible ambient temperature		°C	-5 ... +40
Resistance to climate At 95 % relative humidity	Acc. to DIN 50015	°C	45

BETA Switching

Switches and Light Indicators





5TE8 control switches

Selection and ordering data

	Version	I_e A	U_e V AC	Conductor cross- sections Up to mm ²	MW	DT	Order No.	Price per PU	PG	PU Unit(s)	PS*/ P. unit Unit(s)	Weight per PU approx. kg
	Two-way switches (20 A)											
	With sealable switch position, separate handle locking device can be retrofitted											
	Mountable auxiliary switch											
	1 NO + 1 NC	20	400	6	1	▶	5TE8 151		027	1	1	0.062
	Auxiliary switch cannot be retrofitted											
	2 NO + 2 NC	20	400	6	1	B	5TE8 152		027	1	1	0.081
	3 NO + 1 NC	20	400	6	1	B	5TE8 153		027	1	1	0.082
	1 CO	20	230	6	1	▶	5TE8 161		027	1	1	0.060
	2 CO	20	400	6	1	▶	5TE8 162		027	1	1	0.076
	Group switches with center position (20 A)											
	With sealable switch position, separate handle locking device can be retrofitted											
	Auxiliary switch cannot be retrofitted											
	1 CO contact	20	230	6	1	▶	5TE8 141		027	1	1	0.060
	2 CO contacts	20	400	6	1	▶	5TE8 142		027	1	1	0.077
	Control switches (20 A)											
	With fixed mounted glow lamp 230 V or diode 48 V, with replaceable, white transparent luminescent cap, with sealable switch position separate handle locking device can be retrofitted											
	Auxiliary switch cannot be retrofitted											
	1 NO	20	230	6	1	▶	5TE8 101		027	1	1	0.057
		20	48	6	1	B	5TE8 101-3		027	1	1	0.057
	1 NO, for max. 150 m cable length	20	230	6	1	B	5TE8 105		027	1	1	0.057
	2 NO	20	400	6	1	B	5TE8 102		027	1	1	0.066
	3 NO	20	400	6	1	B	5TE8 103		027	1	1	0.078
With mounted auxiliary switch (1 NO, 1 NC)												
3 NO	20	400	6	1.5	B	5TE8 108		027	1	1	0.128	

BETA Switching Switches and Light Indicators

5TE8 control switches

Version	MW	DT	Order No.	Price per PU	PG	PU	PS*/P. unit	Weight per PU approx.
						Unit(s)	Unit(s)	kg
Auxiliary switches (AS)								
For right-side retrofitting with factory-fitted brackets, for further technical specifications, see chapter "Miniature Circuit Breakers"								
	1 NO + 1 NC	0.5 ▶	5ST3 010		027	1	1	0.050
	2 NO	0.5 A	5ST3 011		027	1	1	0.050
	2 NC	0.5 A	5ST3 012		027	1	1	0.050
Handle locking devices								
For all 5TE8 switches, can be sealed against unwanted manual ON/OFF switching For padlock with max. 3 mm shackle								
		A	5ST3 801		027	1	1	0.008
Spacers								
Contour for modular devices with a mounting depth of 70 mm; can be snapped onto either side of the busbar, so that two spacers allow for convenient cable routing								
	0.5 ▶		5TG8 240		027	1	2	0.010
Cap sets								
For manual changing of the luminous plates for 5TE8 10 control switches								
		C	5TG8 068		027	1 set	1 set	0.006

For busbars for control switch, see page 7/22.

BETA Switching Switches and Light Indicators

5TE8 control switches

Dimensional drawings

Two-way switches, group switches with center position, 20 A

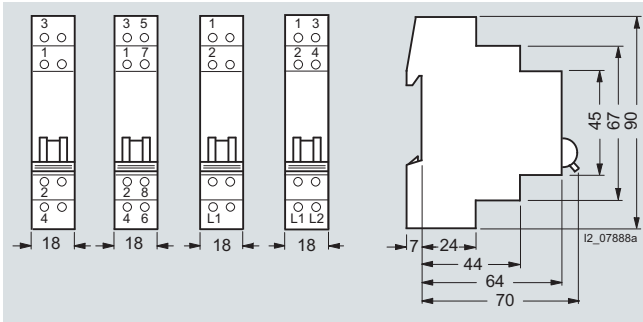

- 5TE8 151 5TE8 152 5TE8 141 5TE8 142
- 5TE8 153 5TE8 161 5TE8 162

5TE8 control switches, 20 A, with lamp

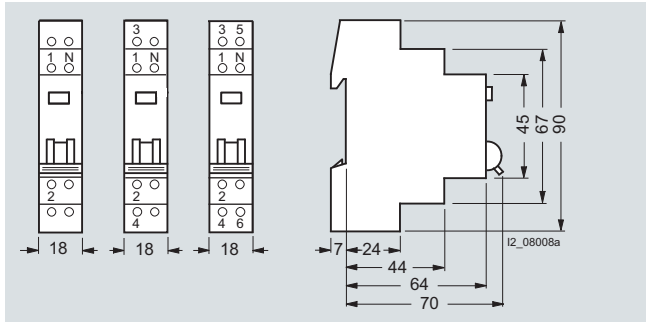

- 5TE8 101 5TE8 102 5TE8 103
- 5TE8 101-3
- 5TE8 105

5TE8 control switches, 20 A, with lamp and auxiliary switch

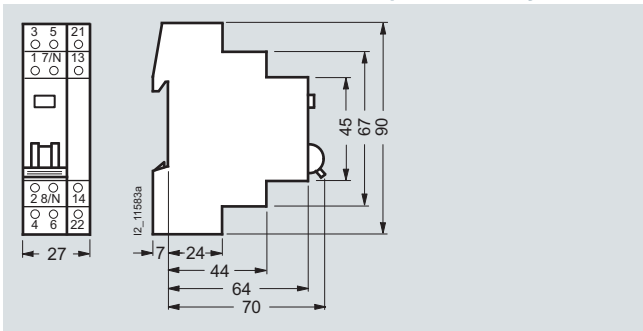

- 5TE8 108

5ST3 auxiliary switches

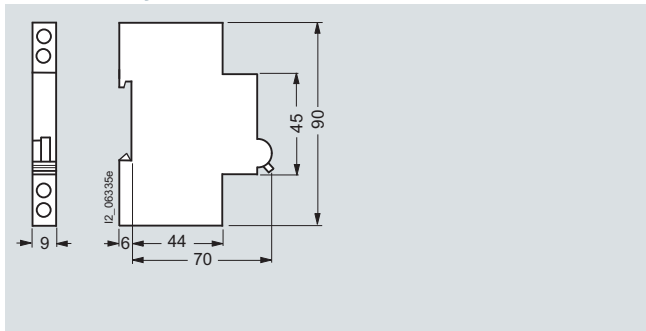

- 5ST3 010
- 5ST3 011
- 5ST3 012

Schematics

Two-way switches, group switches with center position (20 A)

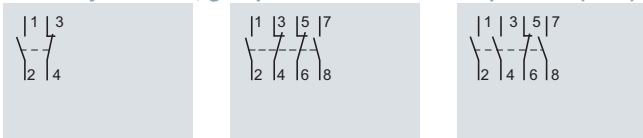

- 5TE8 151
- 5TE8 152
- 5TE8 153

5TE8 control switches, 20 A, with lamp

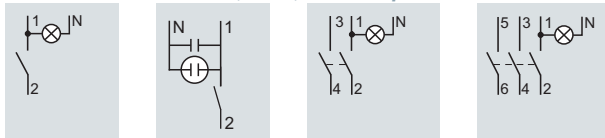

- 5TE8 101
- 5TE8 105
- 5TE8 102
- 5TE8 103

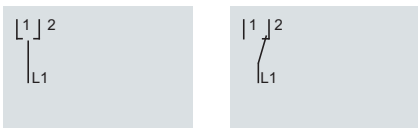

- 5TE8 141
- 5TE8 161

5TE8 control switches, 20 A, with lamp and auxiliary switch

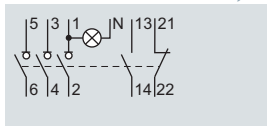

- 5TE8 108

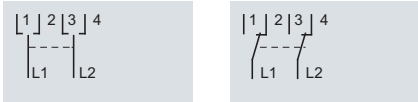

- 5TE8 142
- 5TE8 162

5ST3 auxiliary switches

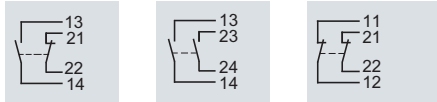

- 5ST3 010
- 5ST3 011
- 5ST3 012

7

Overview

The pushbuttons are used in control systems, e.g. to switch on seal-in circuits or as pushbuttons with maintained-contact function

for manual use, as control switches or for the switching of loads up to 20 A.

Benefits



- Pushbuttons with setting function for momentary-contact or maintained-contact operation can be changed over after installation and connection. This increases the application options of the devices and saves laborious working in the distribution board.



- Pushbuttons and light indicators with separate infeed in one device. This means they can also be used for voltages other than the switching voltage.
- Pushbuttons with remote signaling pilot light in one modular width in momentary-contact or maintained-contact operation save space.



- In the case of devices with 2 pushbuttons and 2 lamps, each pushbutton must be set separately. This increases the application options of devices.

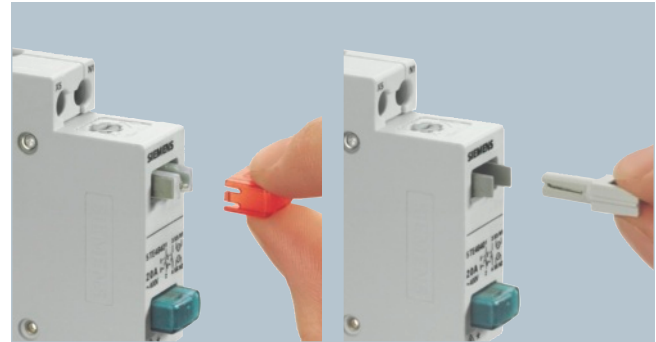

- Pilot lights and caps can also be safely replaced during operation without the use of tools. Functionality is quickly restored.
- Transparent caps in different colors the signaling of system states according to IEC 60073. Three indications per device are possible – this saves mounting space.



- The pilot lights, either glow lamp or diode, depending on the voltage, are nested in a slotted base.

BETA Switching

Switches and Light Indicators

5TE4 pushbuttons





Technical specifications

				5TE4 8
Standards				IEC/EN 60947-3 (VDE 0660-107); IEC/EN 60669-1 (VDE 0632-1) EN 60669-1
Approved acc. to				
Rated operational current I_e	Per conducting path	A		20
Rated operational voltage U_e	1-pole	V AC		230
	Multipole	V AC		400
Rated power dissipation P_V	Per pole	VA		0.6
Thermal rated current I_{the}		A		20
Rated breaking capacity	At p.f. = 0.65	A		60
Rated making capacity	At p.f. = 0.65	A		60
Rated impulse withstand voltage U_{imp}		kV		> 5
Clearances	Open contacts between the poles	mm		2 x > 2
		mm		> 7
Creepage distances		mm		> 7
Mechanical service life	Switching cycles			25000
Minimum contact load		V; mA		10; 300
Rated short-time currents per conducting path at p.f. = 0.7	Up to 0.2 s	A		650
	Up to 0.5 s	A		400
	Up to 1 s	A		290
	Up to 3 s	A		170
(The respective rated surge current can be calculated by multiplying by a factor of 1.5).				
Terminals	± screw (Pozidriv)			1
Max. tightening torque		Nm		1.2
Conductor cross-sections	Rigid	mm ²		1.5 ... 6
	Flexible, with end sleeve	mm ²		1 ... 6
Permissible ambient temperature		°C		-5 ... +40
Resistance to climate at 95 % relative humidity	Acc. to DIN 50015	°C		45

Power loss of 5TG8 05. lamps		5TG8 050	5TG8 051	5TG8 052	5TG8 053	5TG8 054	5TG8 055
Rated operational voltage U_e	V AC	12	24	48	60	115	230
Rated power dissipation P_V	mW	70	160	350	420	70	170
Rated operational voltage U_e	V DC	12	24	48	60	110	220
Rated power dissipation P_V	mW	85	190	450	550	50	135

Color	Color coding according to IEC 60073		
	Safety of people or environment	Process state	System state
Red	Danger	Emergency	Faulty
Yellow	Warning/Caution	Abnormal	
Green	Safety	Normal	
Blue	Stipulation		
White Gray Black	No special significance assigned		

Selection and ordering data

Version	I_e	U_e	Conductor cross-sections	MW	DT	Order No.	Price per PU	PG	PU	PS*/P. unit	Weight per PU approx.	
	A	V AC	Up to mm ²						Unit(s)	Unit(s)	kg	
Pushbuttons without maintained-contact function												
	1 NO, 1 NC 1 gray pushbutton	20	230	6	1	▶	5TE4 800		027	1	1	0.061
	1 NO, 1 NO 1 green pushbutton, 1 blue pushbutton	20	230	6	1	B	5TE4 804		027	1	1	0.053
	1 NO, 1 NC 1 red pushbutton	20	230	6	1	B	5TE4 805		027	1	1	0.061
	1 NO, 1 NC 1 green pushbutton	20	230	6	1	B	5TE4 806		027	1	1	0.061
	1 NO, 1 NC 1 yellow pushbutton	20	230	6	1	B	5TE4 807		027	1	1	0.061
	1 NO, 1 NC 1 blue pushbutton	20	230	6	1	B	5TE4 808		027	1	1	0.061
Pushbuttons with maintained-contact function												
	1 NO, 1 NC 1 gray pushbutton	20	230	6	1	B	5TE4 810		027	1	1	0.060
	2 NO 1 gray pushbutton	20	400	6	1	B	5TE4 811		027	1	1	0.061
	3 NO + N 1 gray pushbutton	20	400	6	1	B	5TE4 812		027	1	1	0.080
	4 NC 1 gray pushbutton	20	400	6	1	B	5TE4 813		027	1	1	0.080
	2 CO 1 gray pushbutton	20	400	6	1	B	5TE4 814		027	1	1	0.075
	Control pushbuttons with maintained-contact function or momentary-contact function and lamp, 230 V For max. 5 m cable length											
	1 NO, 1 NC 1 red pushbutton	20	400	6	1	▶	5TE4 820		027	1	1	0.071
	1 NO 1 red pushbutton	20	230	6	1	▶	5TE4 821		027	1	1	0.078
	2 NO 1 red pushbutton	20	400	6	1	B	5TE4 823		027	1	1	0.080
	2 NC 1 red pushbutton	20	400	6	1	B	5TE4 824		027	1	1	0.080
Control pushbuttons with maintained-contact function or momentary-contact function and lamp, 230 V For max. 150 m cable length												
	1 NO 1 red pushbutton	20	400	6	1	B	5TE4 822		027	1	1	0.078
	Double pushbuttons with maintained-contact function and/or momentary-contact function											
	1 NO and 1 NC 1 red pushbutton, 1 green pushbutton	20	400	6	1	B	5TE4 830		027	1	1	0.065
	1 NO, 1 NC and 1 NO, 1 NC 1 red pushbutton, 1 green pushbutton	20	400	6	1	B	5TE4 831		027	1	1	0.084

* You can order this quantity or a multiple thereof.







BETA Switching

Switches and Light Indicators

5TE4 pushbuttons

Version	I_e	U_e	Conductor cross-sections	MW	DT	Order No.	Price per PU	PG	PU	PS*/P. unit	Weight per PU approx.
	A	V AC	Up to mm ²						Unit(s)	Unit(s)	kg
 Double pushbuttons with maintained-contact function and/or momentary-contact function and two lamps, 230 V For max. 5 m cable length											
1 NO and 1 NO, 1 red pushbutton, 1 green pushbutton	20	400	6	1	B	5TE4 840		027	1	1	0.080
1 NO and 1 NC, 1 red pushbutton, 1 green pushbutton	20	400	6	1	B	5TE4 841		027	1	1	0.080

Version	U_n	DT	Order No.	Price per PU	PG	PU	PS*/P. unit	Weight per PU approx.
	V					Unit(s)	Unit(s)	kg
 Lamps, manually removable for voltages other than 230 V or as spare lamps With inscription label								
LED	12 AC/DC	C	5TG8 050		027	1	1/10	0.001
LED	24 AC/DC	▶	5TG8 051		027	1	1/10	0.001
LED	48 AC/DC	B	5TG8 052		027	1	1/10	0.001
LED	60 AC/DC	B	5TG8 053		027	1	1/10	0.001
Glow lamp	115 AC 110 DC	C	5TG8 054		027	1	1/10	0.001
Glow lamp	230 AC 220 DC	B	5TG8 055		027	1	1/10	0.001

Cap sets, manually replaceable with colored caps With or without lamps											
											
Gray, non-transparent (1 set = 5 units)		D	5TG8 060		027	1 set	1 set	0.002			
											
Red, transparent (1 set = 5 units)		B	5TG8 061		027	1 set	1 set	0.002			
											
Green, transparent (1 set = 5 units)		B	5TG8 062		027	1 set	1 set	0.002			
											
Yellow, transparent (1 set = 5 units)		B	5TG8 063		027	1 set	1 set	0.002			
											
Blue, transparent (1 set = 5 units)		C	5TG8 064		027	1 set	1 set	0.002			
											
Black, non-transparent (1 set = 5 units)		D	5TG8 065		027	1 set	1 set	0.002			
											
White, transparent (1 set = 5 units)		B	5TG8 066		027	1 set	1 set	0.002			
Red and green (1 set contains 10 lamps per color), yellow, blue and white (1 set contains 5 lamps per color)		D	5TG8 067		027	1 set	1 set	0.012			
Red, green, yellow (1 set = 3 units)		C	5TG8 070		027	1 set	1 set	0.002			

Dimensional drawings

5TE4 8 pushbuttons

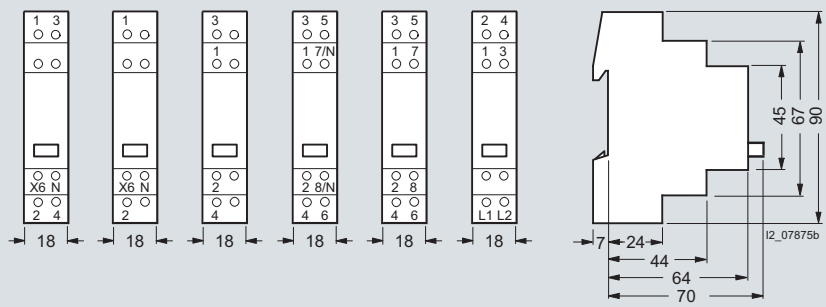

- 5TE4 820 5TE4 821 5TE4 800 5TE4 812 5TE4 813 5TE4 814
- 5TE4 823 5TE4 822 5TE4 805
- 5TE4 824 5TE4 806
- 5TE4 807
- 5TE4 808
- 5TE4 810
- 5TE4 811

5TE4 804 pushbuttons

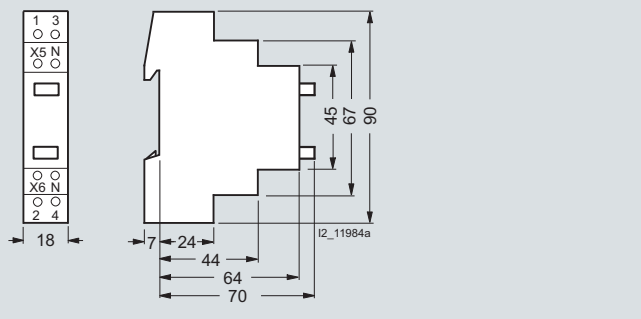

5TE4 804

5TE4 8 double pushbuttons with maintained-contact function

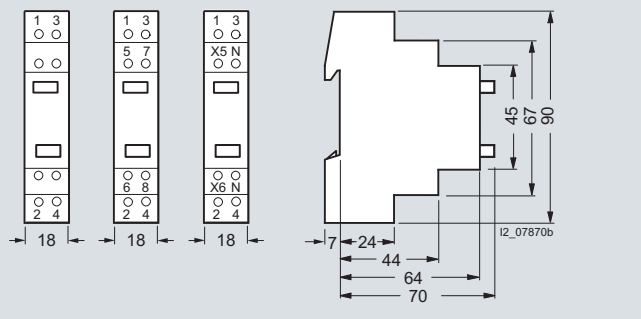

5TE4 830 5TE4 831 5TE4 840
5TE4 841

Schematics

5TE4 8 pushbuttons

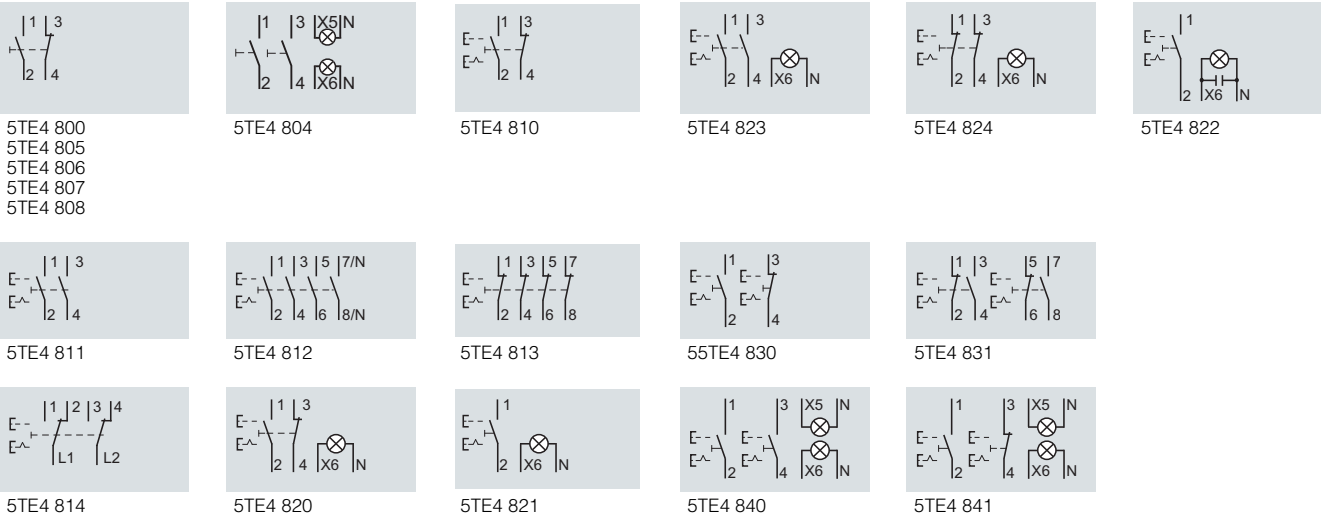

BETA Switching

Switches and Light Indicators

5TE5 light indicators

Overview

Light indicators are used to signal switching states or faults in systems.

They are available as single, double or triple light indicators. The triple light indicators are used as phase or signal indicators.

Benefits



- Pilot lights and caps can also be safely replaced during operation without the use of tools. Functionality is quickly restored.
- Transparent caps in different colors the signaling of system states according to IEC 60073. Three indications per device are possible – this saves mounting space.

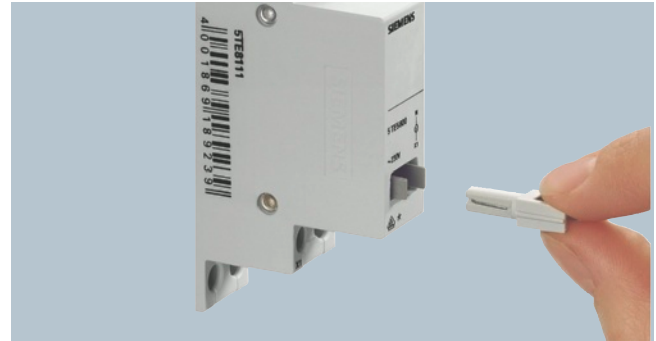

- The pilot lights, either glow lamp or diode, depending on the voltage, are nested in a slotted base. Thus correct polarization is always ensured for DC applications.
- Transparent caps in different colors the signaling of system states according to IEC 60073. Three indications per device are possible – this saves mounting space.



- The devices have preferred positions for the N terminals, so that it is possible to bus-mount several devices. This ensures fast and simple installation.
- The option for busbar mountings is described in the chapter "Miniature Circuit Breakers".



- A light indicator with three lamps enables three-phase signaling and "traffic-light signaling" in a single modular width. This saves valuable installation space and makes things more manageable.

Technical specifications



			5TE5 8
Standards			DIN VDE 0710-1
Rated operational voltage U_e	Max.	V AC	230 (for different voltages see 5TG8 lamps)
Rated power dissipation P_V		VA	See 5TG8 lamps
Clearances	Between the terminals	mm	> 7
Terminals	± screw (Pozidriv)		1
Max. tightening torque		Nm	1.2
Conductor cross-sections	Rigid	mm ²	1.5 ... 6
	Flexible, with end sleeve	mm ²	1 ... 6
Permissible ambient temperature		°C	-5 ... +40
Resistance to climate			
At 95 % relative humidity	Acc. to DIN 50015	°C	45

Color coding according to IEC 60073

			5TG8 05.
Rated power dissipation P_V			
• LED	VA	0.4	
• Glow lamp	VA	0.4	

Color	Meaning		
	Safety of people and environment	Process state	System state
Red	Danger	Emergency	Faulty
Yellow	Warning/Caution	Abnormal	
Green	Safety	Normal	
Blue	Stipulation		
White Gray Black	No special significance assigned		







Selection and ordering data

Version	U_e	Conductor cross-sections	MW	DT	Order No.	Price per PU	PG	PU	PS*/P. unit	Weight per PU approx.
	V AC	Up to mm ²						Unit(s)	Unit(s)	kg
Light indicators for max. cable length up to 5 m										
	With 1 red lamp	230	6	1	▶ 5TE5 800		027	1	1/12	0.060
	With 2 lamps, red and green				▶ 5TE5 801		027	1	1	0.056
	With 3 green lamps				▶ 5TE5 802		027	1	1	0.063
	With 3 lamps, red, yellow and green				▶ 5TE5 803		027	1	1	0.063
Light indicators for max. cable length up to 250 m										
	With 1 red lamp	230	6	1	B 5TE5 804		027	1	1	0.060

BETA Switching

Switches and Light Indicators

5TE5 light indicators

	I_e	U_e	DT	Order No.	Price per PU	PG	PU	PS*/P. unit	Weight per PU approx.	
	mA	V					Unit(s)	Unit(s)	kg	
	Lamps, manually removable for voltages other than 230 V or as spare lamps with inscription label									
	LED	0.4	12 AC/DC	C	5TG8 050		027	1	1/10	0.001
	LED		24 AC/DC	▶	5TG8 051		027	1	1/10	0.001
	LED		48 AC/DC	B	5TG8 052		027	1	1/10	0.001
	LED		60 AC/DC	B	5TG8 053		027	1	1/10	0.001
	Glow lamp		115 AC 110 DC	C	5TG8 054		027	1	1/10	0.001
Glow lamp		230 AC 220 DC	B	5TG8 055		027	1	1/10	0.001	
Cap sets for manual changing of colored caps										
	Red, transparent (1 set = 5 units)			B	5TG8 061		027	1 set	1 set	0.002
	Green, transparent (1 set = 5 units)			B	5TG8 062		027	1 set	1 set	0.002
	Yellow, transparent (1 set = 5 units)			B	5TG8 063		027	1 set	1 set	0.002
	Blue, transparent (1 set = 5 units)			C	5TG8 064		027	1 set	1 set	0.002
	White, transparent (1 set = 5 units)			B	5TG8 066		027	1 set	1 set	0.002
	Red and green (1 set = 10 lamps per color), yellow, blue and white (1 set = 5 lamps per color)			D	5TG8 067		027	1 set	1 set	0.012
	Red, green, yellow (1 set = 3 units)			C	5TG8 070		027	1 set	1 set	0.002

7

Dimensional drawings

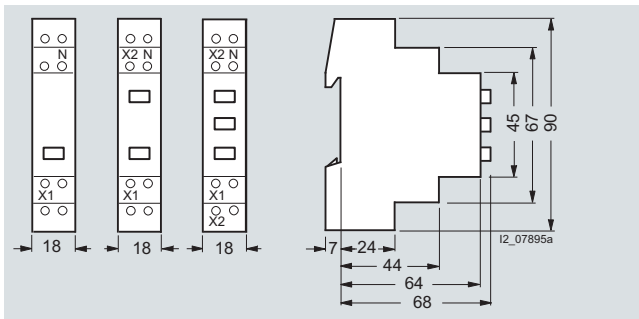

5TE5 800 5TE5 801 5TE5 802
5TE5 804 5TE5 803

Schematics

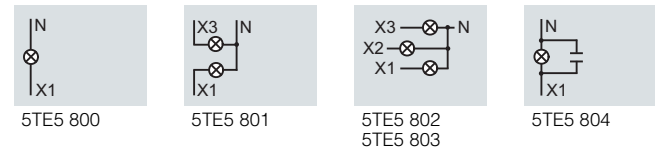

Overview

The devices are used for the switching of lighting, motors and other electrical devices.

The rated currents of the range are 20 to 125 A. There is a compact series of space-saving devices with up to 4 NO contacts in a single MW available for rated currents 20 and 32 A.

The ON/OFF switches in the rated currents (32 to 125 A) can be used as switch disconnectors according to IEC/EN 60947-3.

A special version of the ON/OFF switch with rated current 63 A is available for use in meter cabinets. This version can be locked in the OFF position using a special key. The clamping screws are mechanically covered so that they are no longer accessible.

Benefits

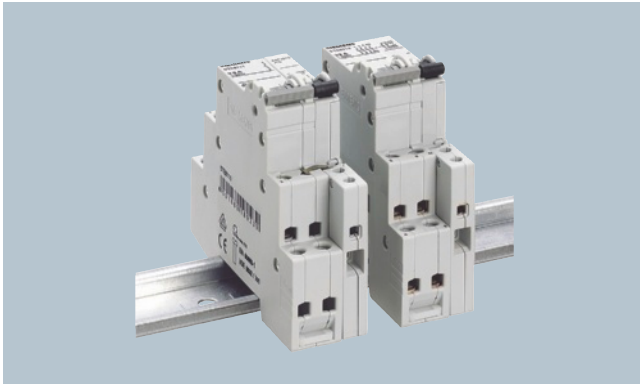

- The switches can be retrofitted with auxiliary switches without the need for tools.
- Uniform auxiliary switches for miniature circuit breakers and switches. So no need to stock-keep additional components.

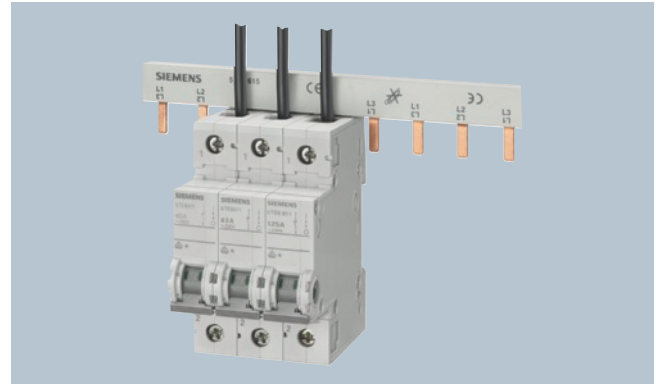

- Clear and visible conductor connection in front of the busbar for safe and easy mounting.
- The infeed can be either from the top or the bottom as the terminals are identical. This simplifies connection.

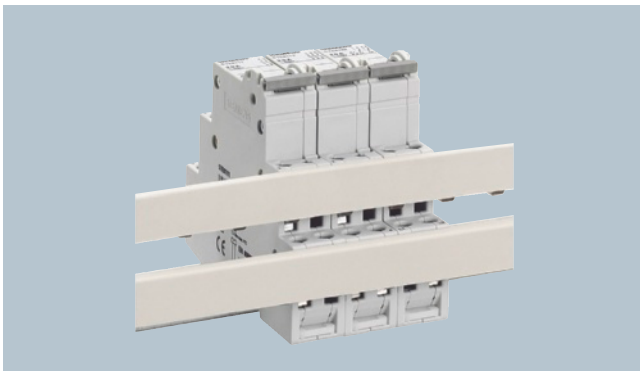

- The 20 and 32 A switches can be bus-mounted with each other or with 5TE4 8 pushbuttons, 5TE5 8 light indicators or 5TT4 1 remote control switches and 5TT4 2 switching relays. This saves time and space.
- For busbars, [see page 7/22](#).

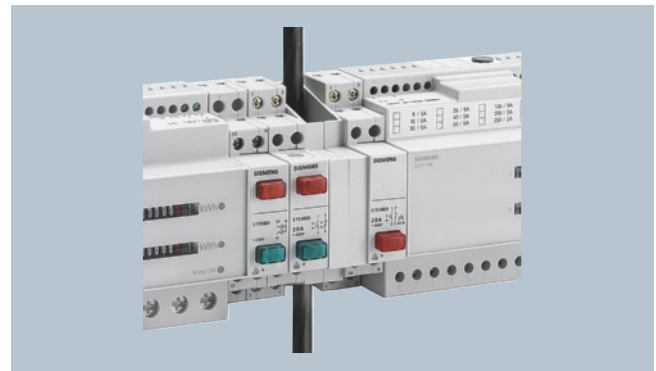

- Spacers can be used as a compensating element and have a width of 0.5 MW. They come with an integrated wiring duct for the insertion of conductors.
- Two reciprocally installed spacers thus offer space for large conductor cross-sections up to a 15 mm diameter. This simplifies cable routing in the distribution board.
- The handle locking device prevents undesired manual on and off switching. This increases operational safety.
- The handle locking device is a universal accessory for all switches and miniature circuit breakers. This simplifies logistics.

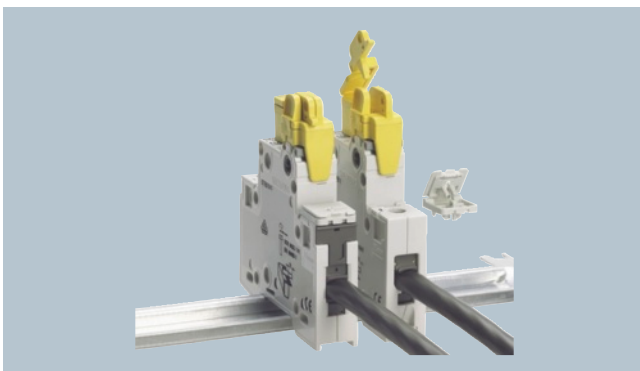

BETA Switching

Switches and Light Indicators

5TE8 ON/OFF switches

Technical specifications

				5TE8 1	5TE8 2	
Standards				IEC/EN 60947-3, (VDE 0660-107); IEC/EN 60669-1	IEC/EN 60947-3, (VDE 0660-107)	
Approved acc. to				EN 60669-1		
Rated operational current I_e	Per conducting path	A	20	32		
Rated operational voltage U_e	1-pole	V AC	230			
	Multipole	V AC	400			
Rated power dissipation P_v	Per pole, max.	VA	0.7			
Thermal rated current I_{th}		A	20	32		
Rated breaking capacity	At p.f. = 0.65	A	60	96		
Rated making capacity	At p.f. = 0.65	A	60	96		
Short-circuit strength						
In conjunction with fuse of the same rated operational current				EN 60269 gL/gG	kA	10
Rated impulse withstand voltage U_{imp}				kV	> 5	
Clearances				Open contacts	mm	2 x > 2
				Between the poles	mm	> 7
Creepage distances				mm	> 7	
Mechanical service life				Switching cycles	25000	
Electrical service life				Switching cycles	10000	
Minimum contact load				V; mA	10; 300	
Rated short-time currents²⁾						
Per conducting path at p.f. = 0.7				Up to 0.2 s	A	650
				Up to 0.5 s	A	400
(The corresponding rated surge current can be established by multiplying by factor 1.5.)				Up to 1 s	A	290
				Up to 3 s	A	170
Terminals				± screw (Pozidriv)		
Max. tightening torque				Nm	1.2	
Conductor cross-sections				Rigid	mm ²	1.5 ... 6
				Flexible, with end sleeve	mm ²	1 ... 6
Permissible ambient temperature				°C	-5 ... +40	
Resistance to climate						
At 95 % relative humidity				Acc. to DIN 50015	°C	45

BETA Switching Switches and Light Indicators

5TE8 ON/OFF switches











			5TE8 3	5TE8 4	5TE8 5	5TE8 6	5TE8 7	5TE8 8	
Standards			IEC/EN 60947-3 (VDE 0660-107)						
Approved acc. to			--	IEC/EN 60669-1 (VDE 0632-1)				--	
Rated operational current I_e	Per conducting path	A	32	40	63	80	100	125	
Rated operational voltage U_e	1-pole Multipole	V AC V AC	230 400						
Rated power dissipation P_v	Per pole, max.	VA	0.7	0.9	2.2	3.5	5.5	8.6	
Thermal rated current I_{th}		A	32	40	63	80	100	125	
Rated breaking capacity	At p.f. = 0.65	A	96	120	196	240	300	375	
Rated making capacity	At p.f. = 0.65	A	96	120	196	240	300	375	
Short-circuit strength	In conjunction with fuse of the same rated operational current	EN 60269 gL/gG	kA	10					
Rated impulse withstand voltage U_{imp}		kV	> 5						
Clearances	Open contacts Between the poles	mm mm	> 7 > 7						
Creepage distances		mm	> 7						
Mechanical service life		Switching cycles	20000						
Electrical service life		Switching cycles	10000		5000	1000			
Minimum contact load		V; mA	24; 300						
Rated power	1-pole	kW	5	6.5	10	13	16	16	
Switching of resistive loads	2-pole	kW	9	11	18	22	28	28	
including moderate overload AC-21	3-/4-pole	kW	15	15	30	39	48	48	
Rated short-time currents²⁾	Per conducting path at p.f. = 0.7								
	Up to 0.2 s	A	760	950	1500	2700	3400	3400	
	Up to 0.5 s	A	500	630	1000	1650	2100	2100	
	Up to 1 s	A	400	500	800	1350	1700	1700	
	Up to 3 s	A	280	350	560	800	1000	1000	
	(The corresponding rated surge current can be established by multiplying by factor 1.5.)								
Terminals	± screw (Pozidriv)		2						
Max. tightening torque		Nm	3.5						
Conductor cross-sections	Rigid	mm ²	1 ... 35			2.5 ... 50			
	Flexible, with end sleeve	mm ²	1 ... 35			2.5 ... 50			
Permissible ambient temperature		°C	-5 ... +40						
Resistance to climate	At 95 % relative humidity	Acc. to DIN 50015	°C	45					

BETA Switching







Switches and Light Indicators

5TE8 ON/OFF switches

Selection and ordering data

Version	I_e	U_e	Conductor cross-sections	MW	DT	Order No.	Price per PU	PG	PU	PS*/P. unit	Weight per PU approx.
A	V AC	Up to mm ²							Unit(s)	Unit(s)	kg
ON/OFF switches (20 A and 32 A)											
With sealable switch position, separate handle locking device can be retrofitted											
Mountable auxiliary switch											
	1 NO	20	230	6	1	▶ 5TE8 111		027	1	1/12	0.053
		32				▶ 5TE8 211		027	1	1	0.053
	2 NO	20	400	6	1	▶ 5TE8 112		027	1	1	0.062
		32				▶ 5TE8 212		027	1	1	0.062
	3 NO	20	400	6	1	B 5TE8 113		027	1	1	0.072
		32				B 5TE8 213		027	1	1	0.072
Auxiliary switch cannot be retrofitted											
	3 NO + N	20	400	6	1	B 5TE8 114		027	1	1	0.082
		32				▶ 5TE8 214		027	1	1	0.081
With mounted auxiliary switch											
	3 NO + N	20	400	6	1.5	B 5TE8 118		027	1	1	0.128
		32				B 5TE8 218		027	1	1	0.128
ON/OFF switches (32 A to 125 A)											
can be used as switch disconnecter according to EN 60947-1											
With sealable switch position, separate handle locking device can be retrofitted, auxiliary switches can be retrofitted											
	1 NO, red handle	63	230	35	1	B 5TE8 521		027	1	1	0.100
		100		50		B 5TE8 721		027	1	1	0.112
	1 NO, gray handle	32		35		B 5TE8 311		027	1	1	0.100
		40				B 5TE8 411		027	1	1	0.100
		63				B 5TE8 511		027	1	1	0.100
		80		50		B 5TE8 611		027	1	1	0.112
	100				B 5TE8 711		027	1	1	0.112	
	125				B 5TE8 811		027	1	1	0.112	
	2 NO, red handle	63	400	35	2	B 5TE8 522		027	1	1	0.204
		100		50		B 5TE8 722		027	1	1	0.225
	2 NO, gray handle	32		35		▶ 5TE8 312		027	1	1	0.204
		40				▶ 5TE8 412		027	1	1	0.204
		63				▶ 5TE8 512		027	1	1	0.204
		80		50		B 5TE8 612		027	1	1	0.225
	100				B 5TE8 712		027	1	1	0.225	
	125				B 5TE8 812		027	1	1	0.225	
	3 NO, red handle	63	400	35	3	B 5TE8 523		027	1	1	0.307
		100		50		B 5TE8 723		027	1	1	0.338
	3 NO, gray handle	32		35		▶ 5TE8 313		027	1	1	0.307
		40				▶ 5TE8 413		027	1	1	0.307
		63				▶ 5TE8 513		027	1	1	0.307
		80		50		▶ 5TE8 613		027	1	1	0.340
	100				▶ 5TE8 713		027	1	1	0.338	
	125				B 5TE8 813		027	1	1	0.338	
	3 NO + N, red handle	63	400	35	4	B 5TE8 524		027	1	1	0.413
		100		50		B 5TE8 724		027	1	1	0.445
	3 NO + N, gray handle	32		35		▶ 5TE8 314		027	1	1	0.410
		40				▶ 5TE8 414		027	1	1	0.410
		63				▶ 5TE8 514		027	1	1	0.413
		80		50		▶ 5TE8 614		027	1	1	0.455
	100				▶ 5TE8 714		027	1	1	0.445	
	125				▶ 5TE8 814		027	1	1	0.455	
	4 NO, gray handle	32		35	4	B 5TE8 315		027	1	1	0.413
		40				B 5TE8 415		027	1	1	0.413
		63				B 5TE8 515		027	1	1	0.413
		80		50		B 5TE8 615		027	1	1	0.455
		100				B 5TE8 715		027	1	1	0.455
		125				B 5TE8 815		027	1	1	0.455

* You can order this quantity or a multiple thereof.

Version	I_e	U_e	Conductor cross-sections	MW	DT	Order No.	Price per PU	PG	PU	PS*/P. unit	Weight per PU approx.
	A	V AC	Up to mm ²						Unit(s)	Unit(s)	kg
	ON/OFF switches (63 A) Can be used as switch disconnecter according to EN 60947-1 Terminal access from the bottom and off-position lockable with special key (exclusive power supply company tool) lockable Reduced lower terminal entry for conductors with approx. 7 mm diameter										
3 NO	63	400	35	3	B	5TE8 533		027	1	1	0.263
	Auxiliary switches (AS) For all 5TE8 switches, for right-side retrofitting with factory-fitted brackets, for further technical specifications, see the chapter "Miniature circuit breakers"										
1 NO + 1 NC				0.5	▶	5ST3 010		027	1	1	0.050
2 NO				0.5	A	5ST3 011		027	1	1	0.050
2 NC				0.5	A	5ST3 012		027	1	1	0.050
Auxiliary switches for small output											
1 NO + 1 NC				0.5	▶	5ST3 013		027	1	1	0.050
2 NO				0.5	B	5ST3 014		027	1	1	0.050
2 NC				0.5	B	5ST3 015		027	1	1	0.050
	Handle locking devices For all 5TE8 switches, can be sealed against unwanted manual ON/OFF switching, padlock with max. 3 mm shackle										
					A	5ST3 801		027	1	1	0.008
	Terminal covers For all 5TE8 5 to 5TE8 8 switches, in 1 MW per pole version, for covering screw openings, sealable										
					B	5ST3 800		027	1	10	0.001
	Spacers Contour for modular devices with a mounting depth of 70 mm; can be snapped onto either side of the busbar, so that two spacers allow for convenient cable routing										
				0.5	▶	5TG8 240		027	1	2	0.010
	Phase connectors For easier wiring in various wiring versions and busbar mountings or as a fixpoint terminal for conductors from 2.5 mm ² to 50 mm ²										
1P	125	230	50	1	B	5TE9 112		027	1	1	0.111
	N-conductor connectors For easier wiring in various wiring versions and busbar mountings or as a fixpoint terminal for N-conductors from 2.5 mm ² to 50 mm ² with blue marking										
1P	125	230	50	1	B	5TE9 113		027	1	1	0.111

BETA Switching

Switches and Light Indicators

5TE8 ON/OFF switches

Dimensional drawings

5TE8 ON/OFF switches (20 A and 32 A)

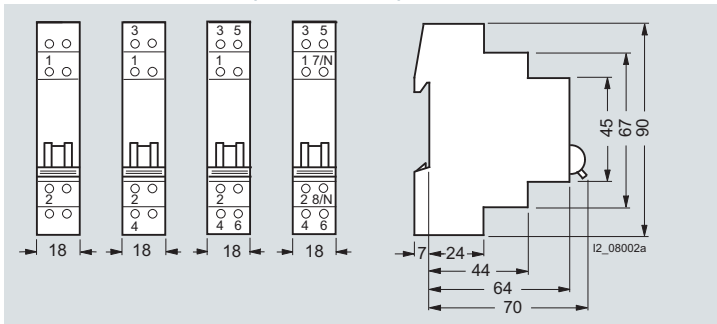

5TE8 111 5TE8 112 5TE8 113 5TE8 114
5TE8 211 5TE8 212 5TE8 213 5TE8 214

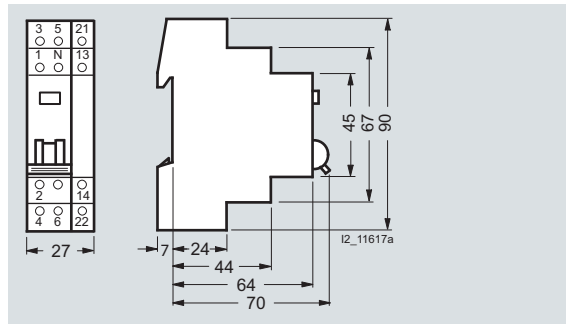

5TE8 118
5TE8 218

5TE8 ON/OFF switches (32 A and 125 A)

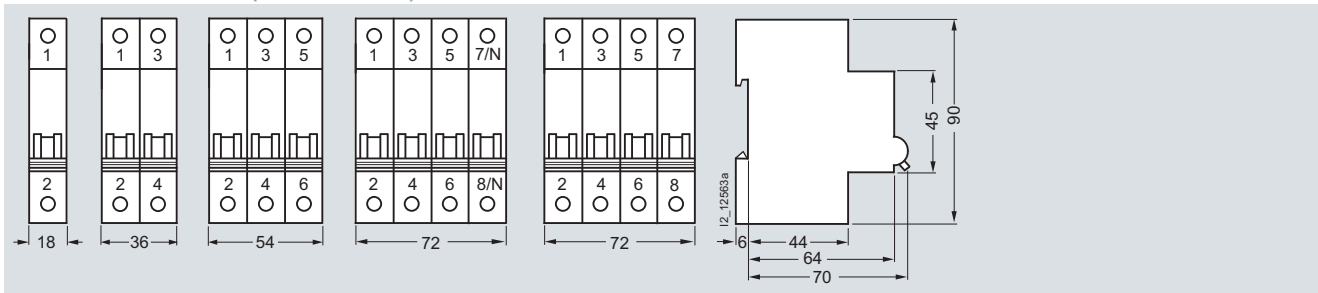

5TE8 311	5TE8 312	5TE8 313	5TE8 314	5TE8 315
5TE8 411	5TE8 412	5TE8 413	5TE8 414	5TE8 415
5TE8 511	5TE8 512	5TE8 513	5TE8 514	5TE8 515
5TE8 521	5TE8 522	5TE8 523	5TE8 524	
		5TE8 533		
5TE8 611	5TE8 612	5TE8 613	5TE8 614	5TE8 615
5TE8 711	5TE8 712	5TE8 713	5TE8 714	5TE8 715
5TE8 721	5TE8 722	5TE8 723	5TE8 724	
5TE8 811	5TE8 812	5TE8 813	5TE8 814	5TE8 815

5ST3 auxiliary switches

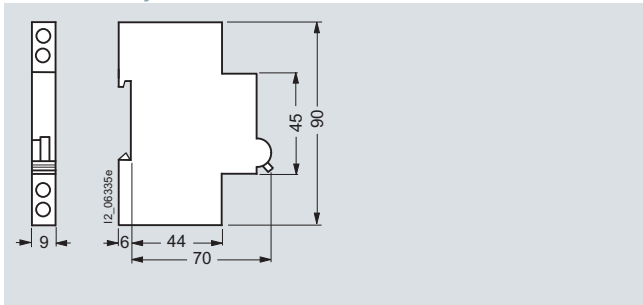

5ST3 010
5ST3 011
5ST3 012

Phase connectors/N-conductor connectors

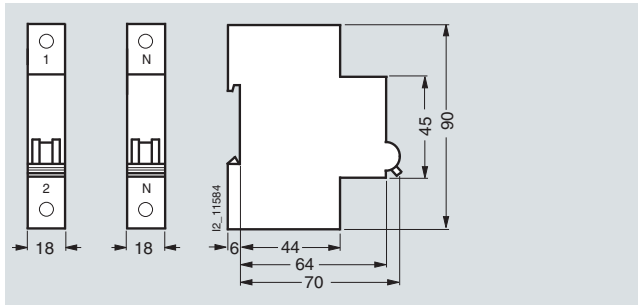

5TE9 112 5TE9 113

7

5TE8 ON/OFF switches

Schematics

5TE8 ON/OFF switches

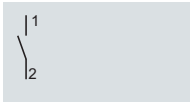

5TE8 111
5TE8 211

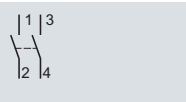

5TE8 112
5TE8 212

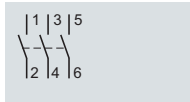

5TE8 113
5TE8 213

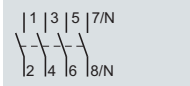

5TE8 114
5TE8 214

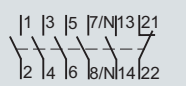

5TE8 118
5TE8 218

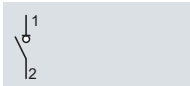

5TE8 311
5TE8 411
5TE8 511
5TE8 521

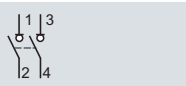

5TE8 312
5TE8 412
5TE8 512
5TE8 522

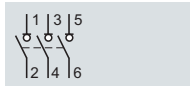

5TE8 313
5TE8 413
5TE8 513
5TE8 523
5TE8 533
5TE8 613
5TE8 713
5TE8 723
5TE8 813

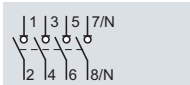

5TE8 314
5TE8 414
5TE8 514
5TE8 524
5TE8 614
5TE8 714
5TE8 724
5TE8 814

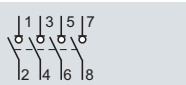

5TE8 315
5TE8 415
5TE8 515
5TE8 615
5TE8 715
5TE8 815

5STE3 auxiliary switches

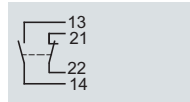

5ST3 010

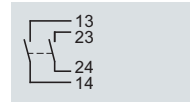

5ST3 011

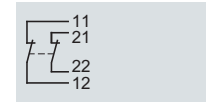

5ST3 012

BETA Switching

Switches and Light Indicators

5TE9 busbars

Overview

Siemens has developed a rail-mounting concept which makes the linking of switching devices just as easy as that of miniature circuit breakers.

The arrangement of the terminals on the devices is adapted to the bus-mounting. With only two busbars, this saves considerable mounting time.

Benefits

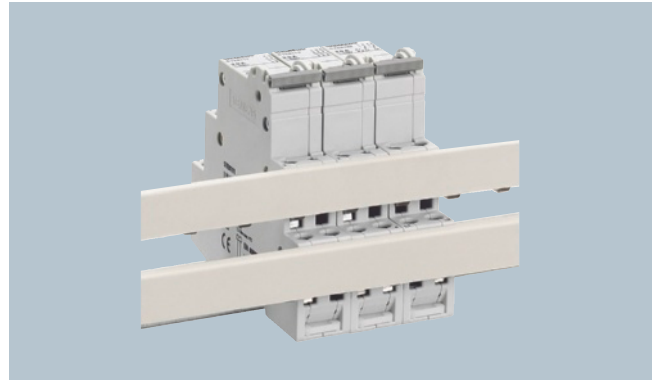
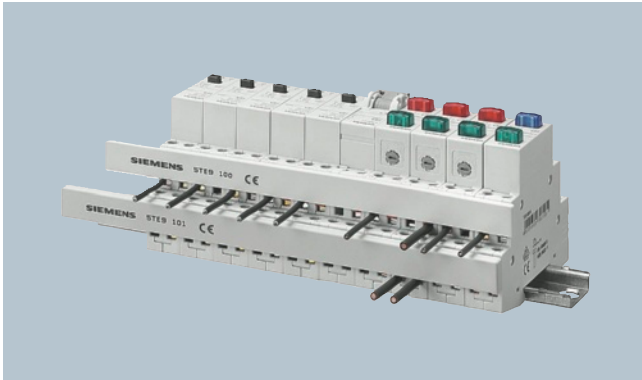

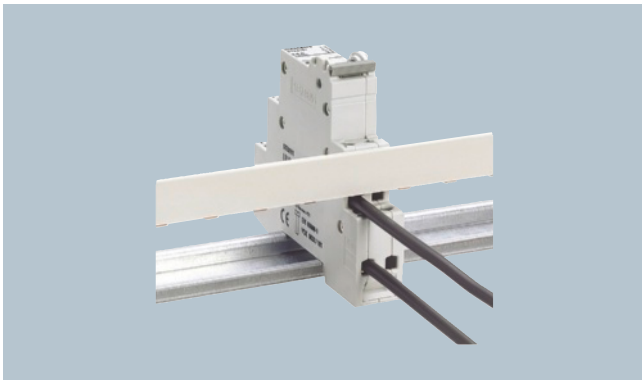

- Uniform bus-mounting on many devices
- All 5TE8 switches (20 and 32 A), 5TE4 8 pushbuttons, 5TE5 8 light indicators and 5TT4 1 remote control switches and 5TT4 2 switching relays can be bus-mounted. This makes installation tasks considerably easier.

- All 5TE8 switches (20 A and 32 A) in 1 MW can be fed via the single or two-phase busbars. Thus 2 two-phase busbars support a 4-pole infeed. This is unique.

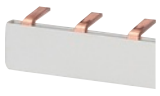
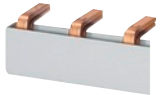

- Infeed: The phase busbar is fed in at the tunnel terminal for conductors up to 6 mm² and 32 A. No additional feeder terminals required.

Selection and ordering data

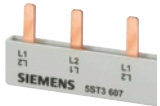
Version	Length mm	DT	Order No.	Price per PU	PG	PU Unit(s)	PS*/ P. unit Unit(s)	Weight per PU approx. kg
 <p>Single-phase busbars For all 5TE8 switches, 20 A and 32 A In the 12 MW version for the cutting of unused terminal lugs to ensure insulation clearances if one device terminal is to be supplied separately despite being mounted on the busbar, modular clearance = 1 MW Infeed of the busbar at the device terminal with a conductor cross-section of 6 mm² to 32 A Can be mounted top or bottom in the front or rear terminal area</p>	210	B	5TE9 100		027	1	10	0.040
 <p>Two-phase busbars For all 5TE8 switches, 20 A and 32 A In 12 MW version with 1 MW division, whereby the two busbars are offset by 0.5 MW Both copper conductors of the two-phase busbar are insulated together. Infeed of the busbar at the device terminal with a conductor cross-section of 6 mm² to 32 A Can be mounted from top or bottom, or in the front or rear terminal area, thus allowing realization of a 4-conductor connection using two two-phase busbars.</p>	220	B	5TE9 101		027	1	10	0.060
 <p>End caps for two-phase busbars End caps for 5TE9 101 two-phase busbars to keep insulation clearances when the bar is being cut. 1 set = 10 units</p>		B	5TE9 102		027	1 set	1 set	0.001
 <p>5ST3 6 and 5ST3 7 busbar systems All bars of the 5ST3 6 and 5ST3 7 busbar systems can also be used for all 1 MW per pole versions of the 5TE8 switches from 32 A to 125 A (see chapter Miniature Circuit Breakers).</p>								

Dimensional drawings

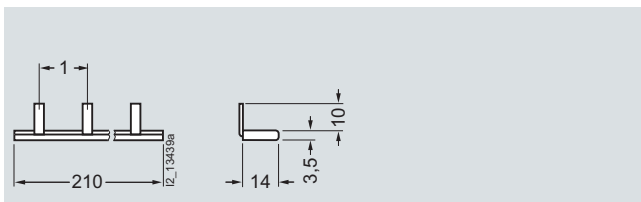

5TE9 100

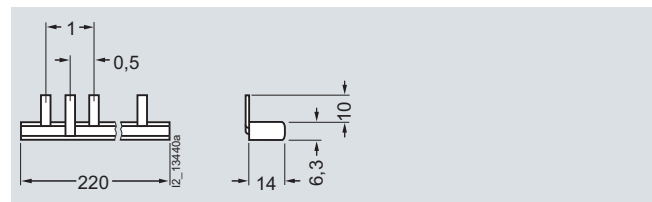

5TE9 101

Note:

Pin spacing in MW.
Dimensions of side views in mm (approx.).

BETA Switching

Switches and Light Indicators

5TE1 switch disconnectors

Overview

The 5TE1 switch disconnectors are available from 100 A to 200 A in 3 and 4-pole versions and can be used as main switches, repair switches, outgoing feeder switches, as well as emergency system interrupters.

The series corresponds to the requirements of IEC/EN 60947-3 and its key features are its compact and robust design, high short-circuit strength, high DC switching capacity and comprehensive accessories.

Its small footprint means it is easy to install in all types of enclosures, distribution boards and control cabinets.

The devices are approved to UL 508 and KEMA certified.



Benefits

- Transparent enclosures ensure that the contact position is always visible
- Contacts with double breaks ensure reliable insulation characteristics
- Can be locked in the OFF position to allow for maintenance work
- With a red knob and yellow cap, it can also be used as an emergency system interrupter.

Technical specifications

		5TE1 .1	5TE1 .2	5TE1 .3	5TE1 .4	
Standards		IEC/EN 60947-3, UL 508				
Approved acc. to		UL 508 for the following types: 5TE1 320, 5TE1 330, 5TE1 340, 5TE1 420, 5TE1 430 and 5TE1 440. UL File No. E302554				
Rated operational current I_e With utilization category AC-21A	Per conducting path at $U_e =$	400 V DC A 415 V DC A 500 V DC A 690 V DC A	100 100 100 100	125 125 125 125	160 160 160 160	200 200 200 200
Rated operational current I_e With utilization category AC-22A	Per conducting path at $U_e =$	400 V DC A 415 V DC A 500 V DC A 690 V DC A	100 100 100 63	125 125 100 63	160 160 160 160	200 200 200 200
Rated operational current I_e With utilization category AC-23A	Per conducting path at $U_e =$	400 V DC A 415 V DC A 500 V DC A 690 V DC A	80 80 50 40		125 125 125 63	160 160 125 80
Rated operational current I_e With utilization category DC-23A	2 poles in series 2 poles in series 4 poles in series	110 V DC A 220 V DC A 220 V DC A	100 -- 100		160 100 160	
Rated operational voltage U_e		V AC	Acc. to UL: 480, acc. to IEC: 690			
Rated insulation voltage U_i		V AC	690			
Rated impulse withstand voltage U_{imp}	2000 m	kV	8			
Impulse test voltage	At sea level	kV	12.3			
Max. rated operational power With utilization category AC-23A	At $U_e =$	400 V DC kW 415 V DC kW 500 V DC kW 690 V DC kW	44 46 35 36		69 72 86 60	88 92 86 76
Thermal rated current I_{th}	At 40 °C, 50 °C and 60 °C	A	100	125	160	200
Rated making capacity	At 415 V AC-23A	A	1875		3200	4000
Rated breaking capacity	At 415 V AC-23A	A	1000		1920	2400
Rated short-circuit making capacity I_{cm}	Per conducting path At $U_e =$	400 V DC kA 415 V DC kA 500 V DC kA 690 V DC kA	10 10 6.7 6.7			
Rated short-time withstand current I_{cw} (peak value)	Per conducting path	0.25 s 1 s	kA kA	5 2.5	6 3	
Rated conditional short-circuit current With back-up protection with back-up fuse With identical rated current	At $U_e =$	400 V DC kA 415 V DC kA 500 V DC kA 690 V DC kA	50 50 50 33	33	20	18
Capacitive load	At 400 V	kVar	50	60	77	97
Number of poles			2/3/4			
Rated power dissipation P_v	Per pole	VA	2.9	4.5	6.5	10
Frequency		Hz	50/60			
Conductor cross-sections						
• Solid and stranded		mm ²	6 ... 50		--	
• AWG cables		mm ²	10 ... 1/0		8	
• Copper busbars		mm ²	--		Max. 20 x 6	
Service life	Electrical Mechanical	Switching cycles	1500 20000		1000 10000	
Acc. to UL 508	I_n	A	--	80	100	125
UL 508 General Use 480 V	FLA (full load amperes)	A	--	28	34	40
UL 508 manual motor controller 230 V	Power	hp	--	10	25	30
UL 508 manual motor controller 480 V	Power	hp	--	20	15	15
UL 508 short circuit at 480 V	With Class H or K5 fuses	kA	--	10		
	With J fuses	kA	--	50		

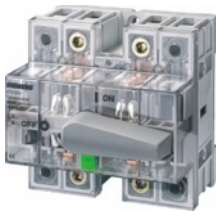





Selection and ordering data

Version	I_e	U_e	MW	DT	Order No.	Price per PU	PG	PU	PS*/P. unit	Weight per PU approx.
	A AC	V AC						Unit(s)	Unit(s)	kg
 <p>Switch disconnectors, lockable, with gray knob and transparent enclosure, mounting depth 92 mm</p>										
2 NO	100	690	5	B	5TE1 210		027	1	1	0.480
	125			B	5TE1 220		027	1	1	0.480
	160		8	B	5TE1 230		027	1	1	0.620
	200			B	5TE1 240		027	1	1	0.620
3 NO	100	690	5	B	5TE1 310		027	1	1	0.540
	125			B	5TE1 320		027	1	1	0.540
	160		8	B	5TE1 330		027	1	1	0.730
	200			B	5TE1 340		027	1	1	0.730
4 NO	100	690	5	B	5TE1 410		027	1	1	0.590
	125			B	5TE1 420		027	1	1	0.590
	160		8	B	5TE1 430		027	1	1	0.770
	200			B	5TE1 440		027	1	1	0.770
3 NO with N-conductor through-type terminal	100	690	5	B	5TE1 610		027	1	1	0.590
	125			B	5TE1 620		027	1	1	0.590
	160		8	B	5TE1 630		027	1	1	0.770
	200			B	5TE1 640		027	1	1	0.770
 <p>Switch disconnectors with red knob and yellow cap, can be used as emergency system interrupter to IEC 60204-1, EN 60204-1 (VDE 0113 -1) If switch is easily accessible, mounting depth 92 mm</p>										
3 NO	100	690	5	B	5TE1 315		027	1	1	0.540
	125			B	5TE1 325		027	1	1	0.540
	160		8	B	5TE1 335		027	1	1	0.730
	200			B	5TE1 345		027	1	1	0.730
4 NO	100	690	5	B	5TE1 415		027	1	1	0.590
	125			B	5TE1 425		027	1	1	0.590
	160		8	B	5TE1 435		027	1	1	0.770
	200			B	5TE1 445		027	1	1	0.770

BETA Switching

Switches and Light Indicators

5TE1 switch disconnectors

	Version	I_e	U_e	DT	Order No.	Price per PU	PG	PU	PS*/P. unit	Weight per PU approx.		
		A AC	V AC					Unit(s)	Unit(s)	kg		
	Terminal covers											
	Sealable											
	For 100 A and 125 A switch disconnectors											
	For 160 A and 200 A switch disconnectors											
				B	5TE9 000		027	1	1	0.060		
				B	5TE9 001		027	1	1	0.050		
	Cage Clamp terminals											
	For switch disconnectors 160 A and 200 A, terminal diameter 14.5 mm for 35 mm ² cables, 5 mm Allen screw											
	1 set = 3 units											
	1 set = 4 units											
				B	5TE9 003		027	1 set	1 set	0.080		
				A	5TE9 004		027	1 set	1 set	0.080		
	Auxiliary switches											
	Can be mounted on the left, the right or both sides (2 units) Minimum contact load 24 V, 50 mA											
	1 CO											
	2 CO											
		6	230	B	5TE9 005		027	1	1	0.080		
		6	230	B	5TE9 006		027	1	1	0.080		
	Locking units											
	For up to three padlocks with max. Ø 8 mm											
				B	5TE9 014		027	1	1	0.230		
	Conversion kits, 4-pole, for 100 A and 125 A, for the connection of busbars or cables with cable lugs											
	For busbars max. 15 mm wide Including terminal cover											
				B	5TE9 015		027	1 set	1 set	0.110		
	Rotary actuators with extension axes for mounting on hinged doors or enclosure lids, lockable, IP65											
	Black knob											
		Axis length 200 mm										
		Axis length 400 mm										
		Red knob										
		Axis length 200 mm										
	Axis length 400 mm											
				B	5TE9 010		027	1	1	0.550		
				B	5TE9 011		027	1	1	0.550		
				B	5TE9 012		027	1	1	0.550		
				B	5TE9 013		027	1	1	0.550		

7

Dimensional drawings

5TE1 switch disconnectors, 100 A and 125 A

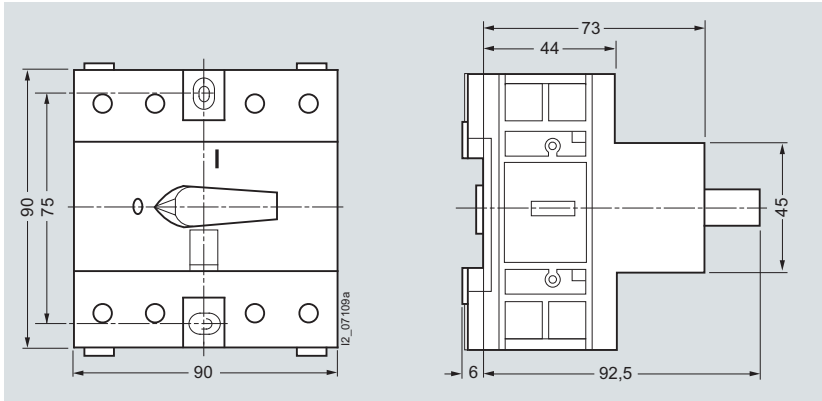

- | | | | |
|----------|----------|----------|----------|
| 5TE1 210 | 5TE1 310 | 5TE1 410 | 5TE1 610 |
| 5TE1 220 | 5TE1 320 | 5TE1 420 | 5TE1 620 |
| | 5TE1 315 | 5TE1 415 | |
| | 5TE1 325 | 5TE1 425 | |

5TE9 auxiliary switches

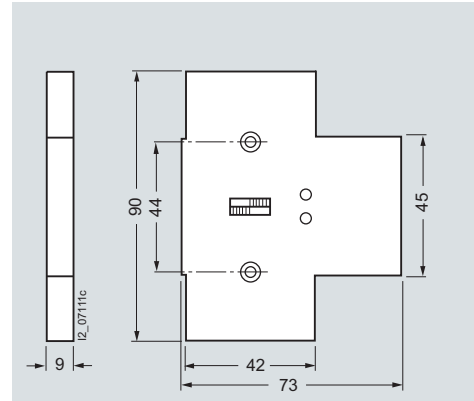

- 5TE9 005
5TE9 006

5TE1 switch disconnectors

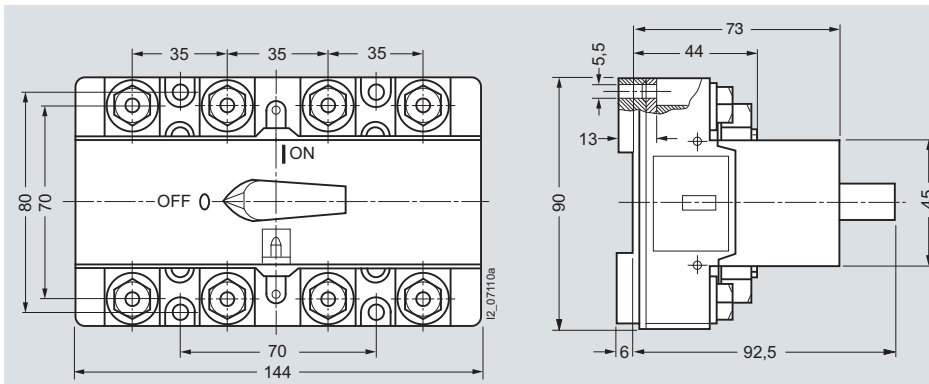

- | | | | |
|----------|----------|----------|----------|
| 5TE1 230 | 5TE1 330 | 5TE1 430 | 5TE1 630 |
| 5TE1 240 | 5TE1 335 | 5TE1 435 | 5TE1 640 |
| | 5TE1 340 | 5TE1 440 | |
| | 5TE1 345 | 5TE1 445 | |

5TE9 014 locking units

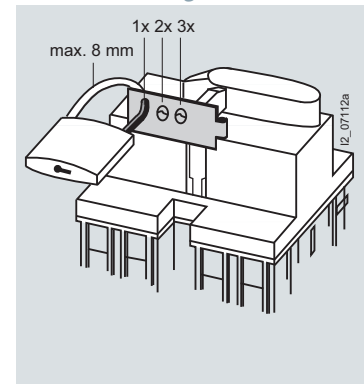

5TE9 rotary actuators with extension axis

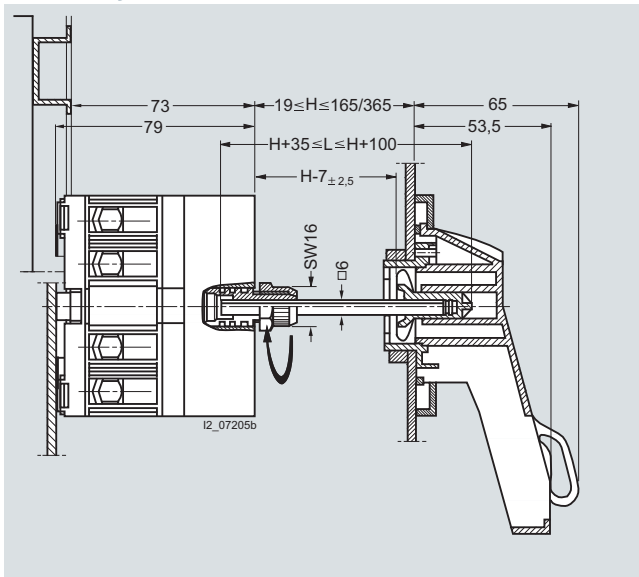

With switch disconnectors 100 A and 125 A,
5TE9 010, 5TE9 011, 5TE9 012, 5TE9 013

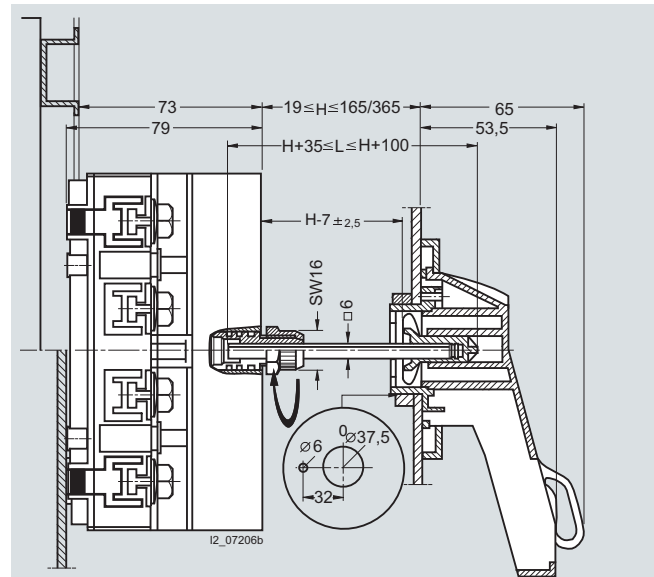

With switch disconnectors 160 A and 200 A,
5TE9 010, 5TE9 011, 5TE9 012, 5TE9 013

It is possible to open the door in both a connected and disconnected state.

BETA Switching

Switches and Light Indicators

5TE1 switch disconnectors

Schematics

5TE1 switch disconnectors



5TE1 210
5TE1 220
5TE1 230
5TE1 240



5TE1 310
5TE1 320
5TE1 330
5TE1 340



5TE1 410
5TE1 420
5TE1 430
5TE1 440



5TE1 610
5TE1 620
5TE1 630
5TE1 640



5TE1 315
5TE1 325
5TE1 335
5TE1 345



5TE1 415
5TE1 425
5TE1 435
5TE1 445

5STE9 auxiliary switches



5TE9 005



5TE9 006

7

More information

Connection of 5TE1 .3 and 5TE1 .4 switches, 160 A and 200 A

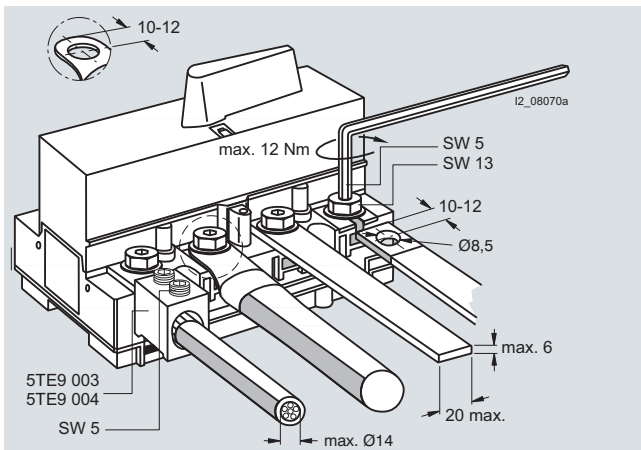

Design

- From 160 A: supplied with one terminal cover
- 160 A and 200 A: version for connection with cable lug
- Screw fixing on base plate
- Installation on standard mounting rail according to EN 60715, which is raised at least 5 mm from the base plate