

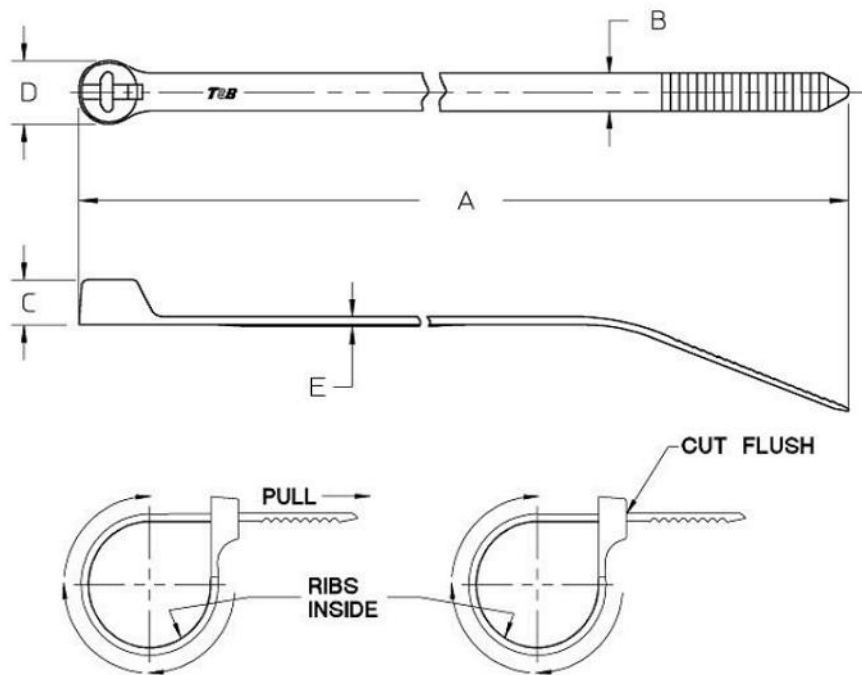

Ty-Rap

**INSTALLATION:**

1. WRAP CABLE TIE AROUND BUNDLE, TEXTURED RIB-SIDE IN.
2. THREAD TAIL OF CABLE TIE THROUGH HEAD UNTIL METAL LOCKING BARB FIRMLY ENGAGES. PULL TAIL THROUGH UNTIL HAND TIGHT.
3. FOR BEST RESULTS, COMPLETE INSTALLATION USING RECOMMENDED INSTALLATION TOOL. RECOMMENDED INSTALLATION TOOL(S): ERG50, ERG120, WT-199A (MS-90387-1)

- MATERIAL: HEAT STABILIZED NYLON CONFORMING TO ASTM D4066 PA121
- MAX. CONTINUOUS USE TEMP: 221°F/105°C
- FLAMMABILITY RATING: UL94-V2

CATALOG NUMBERS:

TYH23M TYH24M TYH25M TYH26M
TYH27M TYH28M

| | | | | | |
|---|--|---|-----------|----------|-------------|
| GENERAL NOTES | | Thomas & Betts A Member of the ABB Group | | | |
| 1. ALL DIMENSIONS ARE FOR REFERENCE ONLY. 2. DIMENSIONS IN BRACKETS [] ARE IN METRIC UNITS. | | | | | |
| REVISIONS | | DESCRIPTION: TY-RAP CABLE TIES (TYH SERIES) HEAT STABILIZED, SELF-CLINCH | | | |
| 0 SEE ERN (****) FOR APPROVAL SIGNATURES & RELEASE DATE. PROJECT NO: **** | | ORIGINAL PROJECT NO / (ERN NO) | SHEET NO: | REV. NO: | DRAWING NO: |
| | | 009C001378 / (2018316) | 1 OF 2 | 0 | WSD-001858 |

| | TYH23M | TYH24M | TYH25M |
|-----------------------------|---------------|---------------|---------------|
| MAX. BUNDLE DIA. IN [mm] | .9 [23] | 1.0 [25] | 1.9 [48] |
| TENSILE LBf [N] | 18 [80] | 40 [180] | 50 [220] |
| A IN [mm] | 3.6 [91] | 5.5 [138] | 7.3 [185] |
| B IN [mm] | 0.09 [2.3] | .14 [3.6] | 0.19 [4.8] |
| C IN [mm] | .15 [3.9] | .18 [4.6] | .22 [5.6] |
| D IN [mm] | .18 [4.6] | .25 [6.4] | .31 [8.0] |
| E IN [mm] | 0.04 [1.0] | 0.05 [1.1] | 0.05 [1.3] |

| | TYH26M | TYH27M | TYH28M |
|-----------------------------|---------------|---------------|---------------|
| MAX. BUNDLE DIA. IN [mm] | 3 [76] | 4 [102] | 4 [102] |
| TENSILE LBf [N] | 40 [180] | 120 [540] | 50 [220] |
| A IN [mm] | 11.1 [281] | 13.5 [343] | 14.2 [360] |
| B IN [mm] | .14 [3.5] | .29 [7.2] | .19 [4.7] |
| C IN [mm] | .18 [4.5] | .49 [7.4] | .22 [5.6] |
| D IN [mm] | .25 [6.3] | .49 [12.6] | .32 [8.0] |
| E IN [mm] | 0.04 [1.0] | 0.06 [1.5] | 0.05 [1.3] |

| | | | |
|---|---------------------|----------------------|---------------------------|
| Thomas&Betts A Member of the ABB Group | | | |
| www.tnb.com | | | |
| DESCRIPTION: TY-RAP CABLE TIES (TYH SERIES) HEAT STABILIZED, SELF-CLINCH | | | |
| | SHEET NO: 2 OF 2 | REV. NO: 0 | DRAWING NO: WSD-001858 |