

SIMATIC

ET 200SP Product information on the documentation of the ET 200SP distributed I/O system

Product Information

Preface

Module overview of
ET 200SP

1

Supplements to ET 200SP
documentation

2

Legal information

Warning notice system

This manual contains notices you have to observe in order to ensure your personal safety, as well as to prevent damage to property. The notices referring to your personal safety are highlighted in the manual by a safety alert symbol, notices referring only to property damage have no safety alert symbol. These notices shown below are graded according to the degree of danger.

⚠ DANGER
indicates that death or severe personal injury will result if proper precautions are not taken.
⚠ WARNING
indicates that death or severe personal injury may result if proper precautions are not taken.
⚠ CAUTION
indicates that minor personal injury can result if proper precautions are not taken.
NOTICE
indicates that property damage can result if proper precautions are not taken.

If more than one degree of danger is present, the warning notice representing the highest degree of danger will be used. A notice warning of injury to persons with a safety alert symbol may also include a warning relating to property damage.

Qualified Personnel

The product/system described in this documentation may be operated only by **personnel qualified** for the specific task in accordance with the relevant documentation, in particular its warning notices and safety instructions. Qualified personnel are those who, based on their training and experience, are capable of identifying risks and avoiding potential hazards when working with these products/systems.

Proper use of Siemens products

Note the following:

⚠ WARNING
Siemens products may only be used for the applications described in the catalog and in the relevant technical documentation. If products and components from other manufacturers are used, these must be recommended or approved by Siemens. Proper transport, storage, installation, assembly, commissioning, operation and maintenance are required to ensure that the products operate safely and without any problems. The permissible ambient conditions must be complied with. The information in the relevant documentation must be observed.

Trademarks

All names identified by ® are registered trademarks of Siemens AG. The remaining trademarks in this publication may be trademarks whose use by third parties for their own purposes could violate the rights of the owner.

Disclaimer of Liability

We have reviewed the contents of this publication to ensure consistency with the hardware and software described. Since variance cannot be precluded entirely, we cannot guarantee full consistency. However, the information in this publication is reviewed regularly and any necessary corrections are included in subsequent editions.

Preface

Validity

This product information supplements the documentation for the ET 200SP and takes precedence over our system manuals, function manuals and product manuals.

Security information

Siemens provides products and solutions with industrial security functions that support the secure operation of plants, systems, machines and networks.

In order to protect plants, systems, machines and networks against cyber threats, it is necessary to implement – and continuously maintain – a holistic, state-of-the-art industrial security concept. Siemens' products and solutions constitute one element of such a concept.

Customers are responsible for preventing unauthorized access to their plants, systems, machines and networks. Such systems, machines and components should only be connected to an enterprise network or the internet if and to the extent such a connection is necessary and only when appropriate security measures (e.g. firewalls and/or network segmentation) are in place.

For additional information on industrial security measures that can be implemented, please visit (<https://www.siemens.com/industrialsecurity>).

Siemens' products and solutions undergo continuous development to make them more secure. Siemens strongly recommends that product updates are applied as soon as they are available and that the latest product versions are used. Use of product versions that are no longer supported, and failure to apply the latest updates may increase customers' exposure to cyber threats.

To stay informed about product updates, subscribe to the Siemens Industrial Security RSS Feed visit (<https://www.siemens.com/industrialsecurity>).

Table of contents

	Preface	3
1	Module overview of ET 200SP	5
1.1	Possible combinations of BaseUnits and I/O modules	5
1.2	CPUs.....	12
1.3	Interface modules.....	13
1.4	BaseUnits.....	15
1.5	I/O modules.....	17
1.6	Motor starters.....	19
1.7	Accessories.....	20
2	Supplements to ET 200SP documentation	25
2.1	System manual	25
2.2	BaseUnits manual.....	27
2.2.1	Special consideration for BaseUnits with functional versions < 04.....	27
2.2.2	Terminal labeling of the PotDis-TB	28
2.3	CPU manuals.....	29
2.4	Interface module manuals.....	30
2.5	I/O module manuals.....	35
2.5.1	Digital module device manuals	37
2.5.2	Analog module device manuals.....	41
2.5.3	Communications module manuals.....	45
2.5.4	Device manuals Technology modules	47

Module overview of ET 200SP

1.1 Possible combinations of BaseUnits and I/O modules

Contents





This product information includes amendments and corrections to the documentation of the ET 200SP Distributed I/O System

(<https://support.industry.siemens.com/cs/ww/en/view/109742709>).

Which I/O modules / motor starters fit on a BaseUnit?

The following table provides an overview of the I/O modules / motor starters that fit on the corresponding compatible BaseUnits:

Table 1- 1 Possible combinations of BaseUnits and I/O modules

I/O module	BaseUnit BU15-		BaseUnit BU20-							Color-coded label for process terminals	
	BU type A0	BU type A1	BU type B0	BU type B1	BU type C0	BU type C1	BU type D0	BU type F0	BU type U0		
	P16+A10+2D	P16+A0+12D/T	P12+A4+0B	P12+A0+4B	P6+A2+4D	P6+A2+4B	P12+A0+0B	P8+A4+0B	P16+A0+2D	P16+A0+2B	
	P16+A0+2D	P16+A0+2D/T									
	P16+A10+2B	P16+A0+12B/T									
	P16+A0+2B	P16+A0+2B/T									
Digital I/O modules											
DI 16x24VDC ST	✓										CC00 
DI 8x24VDC ST	✓										CC01 
DI 8x24VDC HF	✓										CC01 
DI 8x24VDC HS	✓										CC01 
DI 8x24VDC BA	✓										CC01 

1.1 Possible combinations of BaseUnits and I/O modules

I/O module	BaseUnit BU15-		BaseUnit BU20-							Color-coded label for process terminals	
	BU type A0 P16+A10+2D P16+A0+2D P16+A10+2B P16+A0+2B	BU type A1 P16+A0+12D/T P16+A0+2D/T P16+A0+12B/T P16+A0+2B/T	BU type B0 P12+A4+0B	BU type B1 P12+A0+4B	BU type C0 P6+A2+4D	BU type C1 P6+A2+4B	BU type D0 P12+A0+0B	BU type F0 P8+A4+0B	BU type U0 P16+A0+2D P16+A0+2B		
DI 8x24VDC SRC BA	✓									CC02	
DI 8xNAMUR HF	✓									CC01	
DI 4x120..230VAC ST				✓						CC41	
DQ 16x24VDC/0.5A ST	✓									CC00	
DQ 4x24VDC/2A ST	✓									CC02	
DQ 8x24VDC/0.5 ST	✓									CC02	
DQ 8x24VDC/0.5A HF	✓									CC02	
DQ 8x24VDC/0.5A BA	✓									CC02	
DQ 8x24VDC/0.5A SNK BA	✓									CC01	

1.1 Possible combinations of BaseUnits and I/O modules

I/O module	BaseUnit BU15-		BaseUnit BU20-							Color-coded label for process terminals	
	BU type A0 P16+A10+2D P16+A0+2D P16+A10+2B P16+A0+2B	BU type A1 P16+A0+12D/T P16+A0+2D/T P16+A0+12B/T P16+A0+2B/T	BU type B0 P12+A4+0B	BU type B1 P12+A0+4B	BU type C0 P6+A2+4D	BU type C1 P6+A2+4B	BU type D0 P12+A0+0B	BU type F0 P8+A4+0B	BU type U0 P16+A0+2D P16+A0+2B		
DQ 4x24...230VAC/2A ST				✓						CC41	
DQ 4x24...230VAC/2A HF				✓						CC20	
DQ 4x24VDC/2A HF	✓									CC02	
DQ 4x24VDC/2A HS	✓									CC00	
RQ 4x24VUC/2A CO ST	✓									CC00	
RQ 4x120VDC-230VAC/5A NO ST			✓	✓						---	---
RQ 4x120VDC-230VAC/5A NO MA ST			✓	✓						---	---
Analog I/O modules											
AI 4xRTD/TC 2-/3-/4-wire HF	✓	✓								CC00	
AI 8xRTD/TC 2-wire HF	✓	✓								CC00	
AI 8xU BA	✓	✓								CC02	

1.1 Possible combinations of BaseUnits and I/O modules

I/O module	BaseUnit BU15-		BaseUnit BU20-							Color-coded label for process terminals	
	BU type A0 P16+A10+2D P16+A0+2D P16+A10+2B P16+A0+2B	BU type A1 P16+A0+12D/T P16+A0+2D/T P16+A0+12B/T P16+A0+2B/T	BU type B0 P12+A4+0B	BU type B1 P12+A0+4B	BU type C0 P6+A2+4D	BU type C1 P6+A2+4B	BU type D0 P12+A0+0B	BU type F0 P8+A4+0B	BU type U0 P16+A0+2D P16+A0+2B		
AI 2xU ST	✓	✓								CC00	
AI 2xI 2-/4-wire ST	✓	✓								CC05	
AI 4xU/I 2-wire ST	✓	✓								CC03	
AI 2xU/I 2-/4-wire HF	✓	✓								CC05	
AI 2xU/I 2-/4-wire HS	✓	✓								CC00	
AI 8xI 2-/4-wire BA	✓	✓								CC01	
AI 4xI 2-/4-wire ST	✓	✓								CC03	
AI 4xI 2-wire 4...20mA HART	✓	✓								CC03	
AQ 2xU ST	✓	✓								CC00	

1.1 Possible combinations of BaseUnits and I/O modules

I/O module	BaseUnit BU15-		BaseUnit BU20-							Color-coded label for process terminals	
	BU type A0 P16+A10+2D P16+A0+2D P16+A10+2B P16+A0+2B	BU type A1 P16+A0+12D/T P16+A0+2D/T P16+A0+12B/T P16+A0+2B/T	BU type B0 P12+A4+0B	BU type B1 P12+A0+4B	BU type C0 P6+A2+4D	BU type C1 P6+A2+4B	BU type D0 P12+A0+0B	BU type F0 P8+A4+0B	BU type U0 P16+A0+2D P16+A0+2B		
AQ 2xI ST	✓	✓								CC00	
AQ 4xU/I ST	✓	✓								CC00	
AQ 2xU/I HS	✓	✓								CC00	
AQ 2xU/I HF	✓	✓								CC00	
AI Energy Meter 400VAC ST							✓			---	---
AI Energy Meter 480VAC ST							✓			---	---
AI Energy Meter 480VAC/CT HF									✓	CC20	
AI Energy Meter 480VAC/RC HF									✓	CC20	

1.1 Possible combinations of BaseUnits and I/O modules

I/O module	BaseUnit BU15-		BaseUnit BU20-							Color-coded label for process terminals		
	BU type A0	BU type A1	BU type B0	BU type B1	BU type C0	BU type C1	BU type D0	BU type F0	BU type U0			
	P16+A10+2D	P16+A0+12D/T	P12+A4+0B	P12+A0+4B	P6+A2+4D	P6+A2+4B	P12+A0+0B	P8+A4+0B	P16+A0+2D	P16+A0+2B		
	P16+A0+2D	P16+A0+2D/T										
	P16+A10+2B	P16+A0+12B/T										
	P16+A0+2B	P16+A0+2B/T										
Fail-safe modules												
F-PM-E 24VDC/8A PPM ST					✓						CC52	
F-DI 8x24VDC HF	✓										CC01	
F-DQ 4x24VDC/2A PM HF	✓										CC02	
F-DQ 8x24VDC/0.5A PP HF	✓										CC02	
F-RQ 1x24VDC/24..230VA C/5A								✓			CC42	
F-AI 4xI 0(4)..20mA 2-/4-wire HF	✓	✓									CC00	
Communication modules												
CM 4xIO-Link	✓										CC04	
CM AS-i Master ST					✓						---	---
F-CM AS-i Safety ST					✓	✓					---	---
CM PtP	✓										---	---
Technology modules												
TM Count 1x24V	✓										---	---
TM PosInput 1	✓										---	---
TM Timer DIDQ 10x24V	✓										---	---
TM Pulse 2x24V				✓							---	---
SIWAREX WP321	✓										---	---

1.1 Possible combinations of BaseUnits and I/O modules

Table 1- 2 Possible combinations of BaseUnits and motor starters

Motor starters	BaseUnit BU30-						Color-coded label for process terminals
	MS1 with infeed 24 V DC and 500 V AC	MS2 with infeed 500 V AC	MS3 with infeed 24 V DC	MS4 without in- feed	MS5 with in- feed 500 V AC and F-DI ter- minals	MS6 without infeed with F-DI terminals	
Direct starter							
DS 0.3 - 1 A HF			✓			✓*	---
DS 0.9 - 3 A HF			✓			✓*	---
DS 2.8 - 9 A HF			✓			✓*	---
DS 4.0 - 12 A HF			✓			✓*	---
Reversing starter							
RS 0.3 - 1 A HF			✓			✓*	---
RS 0.9 - 3 A HF			✓			✓*	---
RS 2.8 - 9 A HF			✓			✓*	---
RS 4.0 - 12 A HF			✓			✓*	---
Failsafe direct starter							
F-DS 0.3 - 1 A HF			✓			✓	---
F-DS 0.9 - 3 A HF			✓			✓	---
F-DS 2.8 - 9 A HF			✓			✓	---
F-DS 4.0 - 12 A HF			✓			✓	---
Fail-safe reversing starter							
F-RS 0.3 - 1 A HF			✓			✓	---
F-RS 0.9 - 3 A HF			✓			✓	---
F-RS 2.8 - 9 A HF			✓			✓	---
F-RS 4.0 - 12 A HF			✓			✓	---

* The F-DI terminals do not have a function in this combination.

Table 1- 3 Combination possibilities between potential distributor BaseUnit and potential distributor terminal block

Potential distributor terminal block	Potential distributor BaseUnit			
	PotDis-BU-P1/D-R	PotDis-BU-P1/B-R	PotDis-BU-P2/D-B	PotDis-BU-P2/B-B
PotDis-TB-P1-R	✓	✓	✓	✓
PotDis-TB-P2-B	✓	✓	✓	✓
PotDis-TB-n.c.-G	✓	✓	✓	✓
PotDis-TB-BR-W	✓	✓	✓	✓

1.2 CPUs

CPUs

CPU	Number in pack	Article number
CPU 1510SP-1 PN with server module	Pack of 1	6ES7510-1DJ0x-0AB0
CPU 1510SP F-1 PN with server module	Pack of 1	6ES7510-1SJ0x-0AB0
CPU 1512SP-1 PN with server module	Pack of 1	6ES7512-1DK0x-0AB0
CPU 1512SP F-1 PN with server module	Pack of 1	6ES7512-1SK0x-0AB0
CPU 1515SP PC with server module	Pack of 1	6ES7677-2AAxx-0xx0

Important differences between CPUs...PN				
Features	CPU 1510SP-1 PN	CPU 1510SP F-1 PN	CPU 1512SP-1 PN	CPU 1512SP F-1 PN
Bus connection	PROFINET: BusAdapter (port 1, 2) <ul style="list-style-type: none"> • BA 2xRJ45 (as of firmware version 1.6) • BA 2xFC (as of firmware version V1.6) RJ45, integrated (port 3)		PROFINET: BusAdapter (port 1, 2) <ul style="list-style-type: none"> • BA 2xRJ45 (as of firmware version 1.6) • BA 2xFC (as of firmware version V1.6) • BA 2xSCRJ (as of firmware V1.8)¹ • BA SCRJ/RJ45 (as of firmware V1.8)¹ • BA SCRJ/FC (as of firmware V1.8)¹ • BA 2xLC (as of firmware V2.0)¹ • BA LC/RJ45 (as of firmware V2.0)¹ • BA LC/FC (as of firmware V2.0)¹ RJ45, integrated (port 3)	
	PROFIBUS: PROFIBUS DP connection socket via CM DP communication module			
Number of modules	64			
Data work memory	750 KB	750 KB	1 MB	1 MB
Code work memory	100 KB	150 KB	200 KB	300 KB
Address space	1280 bytes/2560 bytes ²			
Multi hot-swapping	Yes			
Can be used for safety applications (supports PROFIsafe V2.0)	No	Yes	No	Yes

¹ Only with article numbers 6ES7512-1DK01-0AB0 and 6ES7512-1SK01-0AB0

² Only 6ES7510-1DJ01-0AB0, 6ES7512-1SJ01-0AB0, 6ES7512-1DK01-0AB0 and 6ES7512-1SK01-0AB0 with FW version V2.0

Note

The CM AS-i Master ST and F-CM AS-i Safety ST communication modules are supported as of firmware V1.8 of the CPUs. Note the following additional requirements:

CM AS-i Master ST:

- Firmware version of the CM AS-i Master ST: V1.1
- STEP 7 (TIA Portal): V13 SP1 Update 4 or higher

F-CM AS-i Safety ST

- Firmware version of the CM AS-i Safety ST: V1.0
- STEP 7 (TIA Portal): as of V13 SP1 Update 4 and HSP0070 V3.0

1.3 Interface modules

Interface modules

Interface modules	Number in pack	Article number
Interface module IM 155-6 PN BA	Pack of 1	6ES7155-6AR00-0AN0
Interface module IM 155-6 PN ST		
<ul style="list-style-type: none"> • with BusAdapter BA 2xRJ45 and server module 	Pack of 1	6ES7155-6AA01-0BN0
<ul style="list-style-type: none"> • with server module 	Pack of 1	6ES7155-6AU01-0BN0
Interface module IM 155-6 PN/2 HF with server module	Pack of 1	6ES7155-6AU01-0CN0
Interface module IM 155-6 PN/3 HF with server module	Pack of 1	6ES7155-6AU30-0CN0
Interface module IM 155-6 PN HS with server module	Pack of 1	6ES7155-6AU00-0DN0
Interface module IM 155-6 DP HF with PROFIBUS FastConnect bus connector (6ES7972-0BB70-0XA0) and server module	Pack of 1	6ES7155-6BA01-0CN0

1.3 Interface modules

Important differences between the interface modules					
Features	IM 155-6 PN BA	IM 155-6 PN ST	IM 155-6 PN/2 HF IM 155-6 PN/3 HF	IM 155-6 PN HS	IM 155-6 DP HF
Bus connection	PROFINET: 2xRJ45, integrated	PROFINET: BusAdapter <ul style="list-style-type: none"> BA 2xRJ45 (as of firmware V1.0) BA 2xFC (as of firmware V1.0) 	PROFINET: BusAdapter <ul style="list-style-type: none"> BA 2xRJ45 (as of firmware V2.0) BA 2xFC (as of firmware V2.0) BA 2xSCRJ (as of firmware V2.2) BA SCRJ/RJ45 (as of firmware V3.1) BA SCRJ/FC (as of firmware V3.1) BA 2xLC (as of firmware V3.3) BA LC/RJ45 (as of firmware V3.3) BA LC/FC (as of firmware V3.3) 	PROFINET: BusAdapter <ul style="list-style-type: none"> BA 2xRJ45 (as of firmware V4.0) BA 2xFC (as of firmware V4.0) BA 2xSCRJ (as of firmware V4.0) BA SCRJ/RJ45 (as of firmware V4.0) BA SCRJ/FC (as of firmware V4.0) BA 2xLC (as of firmware V4.0) BA LC/RJ45 (as of firmware V4.0) BA LC/FC (as of firmware V4.0) 	PROFIBUS: PROFIBUS DP connection socket
Number of modules	12	32	64	30	32
RESET button	No	Yes	IM 155-6 PN/2 HF: Yes IM 155-6 PN/3 HF: No	Yes	Not necessary
Address space (I/O data)	32 bytes	798 bytes	1440 bytes	968 bytes	244 bytes
Multi hot-swapping	No	No	Yes	Yes	Yes

Table 1- 4 Station expansion via ET-Connection (mixed configuration ET 200SP/ET 200AL)

Modules	Number in pack	Article number
BU-Send	Pack of 1	6ES7193-6BN00-0NE0
BA-Send 1xFC	Pack of 1	6ES7193-6AS00-0AA0

1.4 BaseUnits

BaseUnits

Table 1- 5 BaseUnits for I/O modules

BU type	BaseUnits (short name)	Color-coded labels*	Packaging unit	Article number
A0	BU15-P16+A10+2D	P16: CC00 to CC05 A10: CC71 to CC73	Pack of 1	6ES7193-6BP20-0DA0
			Pack of 10	6ES7193-6BP20-2DA0
A0	BU15-P16+A0+2D	P16: CC00 to CC05	Pack of 1	6ES7193-6BP00-0DA0
			Pack of 10	6ES7193-6BP00-2DA0
A0	BU15-P16+A10+2B	P16: CC00 to CC05 A10: CC71 to CC73	Pack of 1	6ES7193-6BP20-0BA0
			Pack of 10	6ES7193-6BP20-2BA0
A0	BU15-P16+A0+2B	P16: CC00 to CC05	Pack of 1	6ES7193-6BP00-0BA0
			Pack of 10	6ES7193-6BP00-2BA0
A1	BU15-P16+A0+12D/T	P16: CC00 to CC05 12D: CC74	Pack of 1	6ES7193-6BP40-0DA1
A1	BU15-P16+A0+2D/T	P16: CC00 to CC05	Pack of 1	6ES7193-6BP00-0DA1
A1	BU15-P16+A0+12B/T	P16: CC00 to CC05 12B: CC74	Pack of 1	6ES7193-6BP40-0BA1
A1	BU15-P16+A0+2B/T	P16: CC00 to CC05	Pack of 1	6ES7193-6BP00-0BA1
B0	BU20-P12+A4+0B	A4: CC81 to CC83	Pack of 1	6ES7193-6BP20-0BB0
			Pack of 10	6ES7193-6BP20-2BB0
B1	BU20-P12+A0+4B	P12: CC41	Pack of 1	6ES7193-6BP20-0BB1
C0	BU20-P6+A2+4D	P6: CC51, CC52 A2: CC84 to CC86	Pack of 1	6ES7193-6BP20-0DC0
C1	BU20-P6+A2+4B	P6: CC51 A2: CC84 to CC86	Pack of 1	6ES7193-6BP20-0BC1
D0	BU20-P12+A0+0B	---	Pack of 1	6ES7193-6BP00-0BD0
F0	BU20-P8+A4+0B	P8: CC42	Pack of 1	6ES7193-6BP20-0BF0
U0	BU20-P16+A0+2D	P16: CC00 to CC05	Pack of 1	6ES7193-6BP00-0BU0
			Pack of 10	6ES7193-6BP00-2BU0
U0	BU20-P16+A0+2B	P16: CC00 to CC05	Pack of 1	6ES7193-6BP00-0DU0
			Pack of 10	6ES7193-6BP00-2DU0

* not included in the scope of delivery of the BaseUnit

1.4 BaseUnits

Table 1- 6 BaseUnit PotDis

PotDis type	Potential distributor (short name)	Color coded labels	Packaging unit	Article number
P1	PotDis-BU-P1/D-R	CC62	Pack of 1	6ES7193-6UP00-0DP1
P1	PotDis-BU-P1/B-R	CC62	Pack of 1	6ES7193-6UP00-0BP1
P2	PotDis-BU-P2/D-B	CC63	Pack of 1	6ES7193-6UP00-0DP2
P2	PotDis-BU-P2/B-B	CC63	Pack of 1	6ES7193-6UP00-0BP2

Table 1- 7 BaseUnit PotDis-TB

Terminal block type	Terminal block (short name)	Color coded labels	Packaging unit	Article number
P1	PotDis-TB-P1-R	CC12	Pack of 1	6ES7193-6TP00-0TP1
P2	PotDis-TB-P2-B	CC13	Pack of 1	6ES7193-6TP00-0TP2
N0	PotDis-TB-n.c.-G	CC10	Pack of 1	6ES7193-6TP00-0TN0
P0	PotDis-TB-BR-W	CC10	Pack of 1	6ES7193-6TP00-0TP0

Table 1- 8 BaseUnits for motor starters

BU type	BaseUnits (short name)	Color-coded labels	Packaging unit	Article number
MS1	BU30-MS1	-	Pack of 1	3RK1908-0AP00-0AP0
MS2	BU30-MS2	-	Pack of 1	3RK1908-0AP00-0CP0
MS3	BU30-MS3	-	Pack of 1	3RK1908-0AP00-0BP0
MS4	BU30-MS4	-	Pack of 1	3RK1908-0AP00-0DP0
MS5	BU30-MS5	-	Pack of 1	3RK1908-0AP00-0EP0
MS6	BU30-MS6	-	Pack of 1	3RK1908-0AP00-0FP0

1.5 I/O modules

I/O modules

Digital I/O modules	Number in pack	Article number
DI 16x24VDC ST	Pack of 1	6ES7131-6BH01-0BA0
	Pack of 10	6ES7131-6BH01-2BA0
DI 8x24VDC ST	Pack of 1	6ES7131-6BF01-0BA0
	Pack of 10	6ES7131-6BF01-2BA0
DI 8x24VDC HF	Pack of 1	6ES7131-6BF00-0CA0
	10 units	6ES7131-6BF00-2CA0
DI 8x24VDC HS	Pack of 1	6ES7131-6BF00-0DA0
DI 8xNAMUR HF	Pack of 1	6ES7131-6TF00-0CA0
DI 8x24VDC BA	Pack of 1	6ES7131-6BF01-0AA0
	Pack of 10	6ES7131-6BF01-2AA0
DI 8x24VDC SRC BA	Pack of 1	6ES7131-6BF61-0AA0
DI 4x120..230VAC ST	Pack of 1	6ES7131-6FD01-0BB1
DQ 16x24VDC/0.5A ST	Pack of 1	6ES7132-6BH01-0BA0
	Pack of 10	6ES7132-6BH01-2BA0
DQ 8x24VDC/0.5A ST	Pack of 1	6ES7132-6BF01-0BA0
	Pack of 10	6ES7132-6BF01-2BA0
DQ 8x24VDC/0.5A HF	Pack of 1	6ES7132-6BF00-0CA0
	10 units	6ES7132-6BF00-2CA0
DQ 8x24VDC/0.5A BA	Pack of 1	6ES7132-6BF01-0AA0
	Pack of 10	6ES7132-6BF01-2AA0
DQ 8x24VDC/0.5A SNK BA	Pack of 1	6ES7132-6BF61-0AA0
DQ 4x24VDC/2A ST	Pack of 1	6ES7132-6BD20-0BA0
	Pack of 10	6ES7132-6BD20-2BA0
DQ 4x24..230VAC/2A ST	Pack of 1	6ES7132-6FD00-0BB1
	Pack of 10	6ES7132-6FD00-2BB1
DQ 4x24..230VAC/2A HF	Pack of 1	6ES7132-6FD00-0CU0
DQ 4x24VDC/2A HF	Pack of 1	6ES7132-6BD20-0CA0
DQ 4x24VDC/2A HS	Pack of 1	6ES7132-6BD20-0DA0
RQ 4x24VUC/2A CO ST	Pack of 1	6ES7132-6GD51-0BA0
RQ 4x120VDC-230VAC/5A NO ST	Pack of 1	6ES7132-6HD01-0BB1
	Pack of 10	6ES7132-6HD01-2BB1
RQ 4x120VDC-230VAC/5A NO MA ST	Pack of 1	6ES7132-6MD00-0BB1

1.5 I/O modules

Analog I/O modules	Number in pack	Article number
AI 8xU BA	Pack of 1	6ES7134-6FF00-0AA1
AI 2xU ST	Pack of 1	6ES7134-6FB00-0BA1
AI 4xU/I 2-wire ST	Pack of 1	6ES7134-6HD01-0BA1
	Pack of 10	6ES7134-6HD01-2BA1
AI 2xU/I 2-/4-wire HF	Pack of 1	6ES7134-6HB00-0CA1
AI 2xU/I 2-/4-wire HS	Pack of 1	6ES7134-6HB00-0DA1
AI 8xI 2-/4-wire BA	Pack of 1	6ES7134-6GF00-0AA1
AI 2xI 2-/4-wire ST	Pack of 1	6ES7134-6GB00-0BA1
AI 4xI 2-/4-wire ST	Pack of 1	6ES7134-6GD01-0BA1
	10 units	6ES7134-6GD01-2BA1
AI 8xRTD/TC 2-wire HF	Pack of 1	6ES7134-6JF00-0CA1
	Pack of 10	6ES7134-6JF00-2CA1
AI 4xRTD/TC 2-/3-/4-wire HF	Pack of 1	6ES7134-6JD00-0CA1
	Pack of 10	6ES7134-6JD00-2CA1
AI 4xI 2-wire 4...20mA HART	Pack of 1	6ES7134-6TD00-0CA1
AQ 2xU ST	Pack of 1	6ES7135-6FB00-0BA1
AQ 2xI ST	Pack of 1	6ES7135-6GB00-0BA1
AQ 4xU/I ST	Pack of 1	6ES7135-6HD00-0BA1
AQ 2xU/I HF	Pack of 1	6ES7135-6HB00-0CA1
AQ 2xU/I HS	Pack of 1	6ES7135-6HB00-0DA1
AI Energy Meter 400VAC ST	Pack of 1	6ES7134-6PA01-0BD0
AI Energy Meter 480VAC ST	Pack of 1	6ES7134-6PA20-0BD0
AI Energy Meter 480VAC/CT HF	Pack of 1	6ES7134-6PA00-0CU0
AI Energy Meter 480VAC/RC HF	Pack of 1	6ES7134-6PA20-0CU0

Fail-safe modules	Number in pack	Article number
F-PM-E 24VDC/8A PPM ST	Pack of 1	6ES7136-6PA00-0BC0
F-DI 8x24VDC HF	Pack of 1	6ES7136-6BA00-0CA0
F-DQ 4x24VDC/2A PM HF	Pack of 1	6ES7136-6DB00-0CA0
F-DQ 8x24VDC/0.5A PP HF	Pack of 1	6ES7136-6DC00-0CA0
F-RQ 1x24VDC/24..230VAC/5A	Pack of 1	6ES7136-6RA00-0BF0
F-AI 4xI 0(4)..20mA 2-/4-wire HF	Pack of 1	6ES7136-6AA00-0CA1

Communication modules	Number in pack	Article number
CM 4xIO-Link	Pack of 1	6ES7137-6BD00-0BA0
CM AS-i Master ST	Pack of 1	3RK7137-6SA00-0BC1
F-CM AS-i Safety ST	Pack of 1	3RK7136-6SC00-0BC1
CM PtP	Pack of 1	6ES7137-6AA00-0BA0
CM DP (for CPU)	Pack of 1	6ES7545-5DA00-0AB0

Technology modules	Number in pack	Article number
TM Count 1x24V	Pack of 1	6ES7138-6AA00-0BA0
TM PosInput 1	Pack of 1	6ES7138-6BA00-0BA0
TM Timer DIDQ 10x24V	Pack of 1	6ES7138-6CG00-0BA0
TM Pulse 2x24V	Pack of 1	6ES7138-6DB00-0BB1
SIWAREX WP321	Pack of 1	7MH4138-6AA00-0BA0

1.6 Motor starters

Motor starters

Direct starter	Packaging unit	Article number
DS 0.3 - 1 A HF	Pack of 1	3RK1308-0AB00-0CP0
DS 0.9 - 3 A HF	Pack of 1	3RK1308-0AC00-0CP0
DS 2.8 - 9 A HF	Pack of 1	3RK1308-0AD00-0CP0
DS 4.0 - 12 A HF	Pack of 1	3RK1308-0AE00-0CP0

Reversing starter	Packaging unit	Article number
RS 0.3 - 1 A HF	Pack of 1	3RK1308-0BB00-0CP0
RS 0.9 - 3 A HF	Pack of 1	3RK1308-0BC00-0CP0
RS 2.8 - 9 A HF	Pack of 1	3RK1308-0BD00-0CP0
RS 4.0 - 12 A HF	Pack of 1	3RK1308-0BE00-0CP0











Failsafe direct starter	Number in pack	Article number
F-DS 0.3 - 1 A HF	Pack of 1	3RK1308-0CB00-0CP0
F-DS 0.9 - 3 A HF	Pack of 1	3RK1308-0CC00-0CP0
F-DS 2.8 - 9 A HF	Pack of 1	3RK1308-0CD00-0CP0
F-DS 4.0 - 12 A HF	Pack of 1	3RK1308-0CE00-0CP0

Fail-safe reversing starter	Number in pack	Article number
F-RS 0.3 - 1 A HF	Pack of 1	3RK1308-0DB00-0CP0
F-RS 0.9 - 3 A HF	Pack of 1	3RK1308-0DC00-0CP0
F-RS 2.8 - 9 A HF	Pack of 1	3RK1308-0DD00-0CP0
F-RS 4.0 - 12 A HF	Pack of 1	3RK1308-0DE00-0CP0











1.7 Accessories







Accessories

General accessories	Packaging unit	Article number
BusAdapter		
• BA 2×RJ45 (PROFINET BusAdapter with standard Ethernet socket)	Pack of 1	6ES7193-6AR00-0AA0
• BA 2×FC (PROFINET BusAdapter with FastConnect Ethernet connection)	Pack of 1	6ES7193-6AF00-0AA0
• BA 2xSCRJ (PROFINET BusAdapter with POF/PCF fiber-optic cable connection)	Pack of 1	6ES7193-6AP00-0AA0
• BA SCRJ/RJ45 (media converter, PROFINET BusAdapter with fiber-optic cable FOC ⇔ standard RJ45 connector)	Pack of 1	6ES7193-6AP20-0AA0
• BA SCRJ/FC (media converter, PROFINET bus adapter with fiber-optic cable FOC ⇔ direct connection of bus cable)	Pack of 1	6ES7193-6AP40-0AA0
• BA 2xLC (PROFINET BusAdapter with glass fiber-optic cable connection)	Pack of 1	6ES7193-6AG00-0AA0
• BA LC/RJ45 (media converter, PROFINET BusAdapter with glass fiber-optic cable ⇔ standard RJ45 connector)	Pack of 1	6ES7193-6AG20-0AA0
• BA LC/FC (Media converter, PROFINET bus adapter with glass fiber-optic cable ⇔ direct connection of bus cable)	Pack of 1	6ES7193-6AG40-0AA0
PROFIBUS FastConnect bus connector	Pack of 1	6ES7972-0BB70-0XA0
Server module (spare part)	Pack of 1	6ES7193-6PA00-0AA0
BU cover		
• 15 mm wide	Pack of 5	6ES7133-6CV15-1AM0
• 20 mm wide	Pack of 5	6ES7133-6CV20-1AM0
Shield connector for BaseUnit (shield contacts and shield terminals)	Pack of 5	6ES7193-6SC00-1AM0
Reference identification label, sheet with 16 labels	Pack of 10	6ES7193-6LF30-0AW0
Labeling strips (for labeling the I/O modules)		
• Roll, light gray (with a total of 500 labeling strips)	Pack of 1	6ES7193-6LR10-0AA0
• Roll, yellow (with a total of 500 labeling strips)	Pack of 1	6ES7193-6LR10-0AG0
• DIN A4 sheets, light gray (with a total of 1000 labeling strips)	Pack of 10	6ES7193-6LA10-0AA0
• DIN A4 sheets, yellow (with a total of 1000 labeling strips)	Pack of 10	6ES7193-6LA10-0AG0
Mounting rails, tin-plated steel strip		
• Length: 483 mm	Pack of 1	6ES5710-8MA11
• Length: 530 mm	Pack of 1	6ES5710-8MA21
• Length: 830 mm	Pack of 1	6ES5710-8MA31
• Length: 2000 mm	Pack of 1	6ES5710-8MA41





Accessories, color identification labels (push-in terminals), 15 mm wide	Packaging unit		Article number
16 process terminals (you can find additional information in the I/O Module manual)			
<ul style="list-style-type: none"> Gray (terminals 1 to 16); color code CC00 	Pack of 10		6ES7193-6CP00-2MA0
<ul style="list-style-type: none"> Gray (terminals 1 to 8), red (terminals 9 to 16); color code CC01 	Pack of 10		6ES7193-6CP01-2MA0
<ul style="list-style-type: none"> Gray (terminals 1 to 8), blue (terminals 9 to 16); color code CC02 	Pack of 10		6ES7193-6CP02-2MA0
<ul style="list-style-type: none"> Gray (terminals 1 to 8), red (terminals 9 to 12), gray (terminals 13 to 16); color code CC03 	Pack of 10		6ES7193-6CP03-2MA0
<ul style="list-style-type: none"> Gray (terminals 1 to 8), red (terminals 9 to 12), blue (terminals 13 to 16); color code CC04 	Pack of 10		6ES7193-6CP04-2MA0
<ul style="list-style-type: none"> Gray (terminals 1 to 12), red (terminals 13 and 14), blue (terminals 15 and 16); color code CC05 	Pack of 10		6ES7193-6CP05-2MA0
10 AUX terminals (for BU15-P16+A10+2D, BU15-P16+A10+2B)			
<ul style="list-style-type: none"> Yellow-green (terminals 1A to 10A); color code CC71 	Pack of 10		6ES7193-6CP71-2AA0
<ul style="list-style-type: none"> Red (terminals 1A to 10A); color code CC72 	Pack of 10		6ES7193-6CP72-2AA0
<ul style="list-style-type: none"> Blue (terminals 1A to 10A); color code CC73 	Pack of 10		6ES7193-6CP73-2AA0
10 add-on terminals (for BU15-P16+A0+12D/T, BU15-P16+A0+12B/T)			
<ul style="list-style-type: none"> Red (terminals 1B to 5B), blue (terminals 1 to 5C); color code CC74 	Pack of 10		6ES7193-6CP74-2AA0

1.7 Accessories

Accessories, color identification labels (push-in terminals), 20 mm wide	Packaging unit		Article number
12 process terminals (you can find additional information in the I/O Module manual)			
<ul style="list-style-type: none"> Gray (terminals 1 to 4), red (terminals 5 to 8), blue (terminals 9 to 12); color code CC41 	Pack of 10		6ES7193-6CP41-2MB0
<ul style="list-style-type: none"> Gray (terminals 1 to 8), red (terminals 9 and 10), blue (terminals 11 and 12), color code CC42 	Pack of 10		6ES7193-6CP42-2MB0
6 process terminals (you can find additional information in the I/O Module manual)			
<ul style="list-style-type: none"> Gray (terminals 1 to 4), red (terminal 5), blue (terminal 6); color code CC51 	Pack of 10		6ES7193-6CP51-2MC0
<ul style="list-style-type: none"> Gray (terminals 1, 2 and 5), red (terminals 3 and 4), blue (terminal 6); color code CC52 	Pack of 10		6ES7193-6CP52-2MC0
4 AUX terminals (for BU20-P12+A4+0B)			
<ul style="list-style-type: none"> Yellow-green (terminals 1A to 4A); color code CC81 	Pack of 10		6ES7193-6CP81-2AB0
<ul style="list-style-type: none"> Red (terminals 1A to 4A); color code CC82 	Pack of 10		6ES7193-6CP82-2AB0
<ul style="list-style-type: none"> Blue (terminals 1A to 4A); color code CC83 	Pack of 10		6ES7193-6CP83-2AB0
2 AUX terminals (for BU20-P6+A2+4D, BU20-P6+A2+4B)			
<ul style="list-style-type: none"> Yellow-green (terminals 1A and 2A); color code CC84 	Pack of 10		6ES7193-6CP84-2AC0
<ul style="list-style-type: none"> Red (terminals 1A and 2A); color code CC85 	Pack of 10		6ES7193-6CP85-2AC0
<ul style="list-style-type: none"> Blue (terminals 1A and 2A); color code CC86 	Pack of 10		6ES7193-6CP86-2AC0

Accessories, color identification labels (push-in terminals) PotDis	Packaging unit		Article number
PotDis-BU, 16 potential terminals			
<ul style="list-style-type: none"> Red for PotDis-BU-P1/x-R (terminals 1 to 16); color code CC62 	Pack of 10		6ES7193-6CP62-2MA0
<ul style="list-style-type: none"> Blue for PotDis-BU-P2/x-B (terminals 1 to 16), color code CC63 	Pack of 10		6ES7193-6CP63-2MA0
PotDis-TB-P1-R, 18 potential terminals			
<ul style="list-style-type: none"> Red (terminals 1 to 18); color code CC12 	Pack of 10		6ES7193-6CP12-2MT0
<ul style="list-style-type: none"> Gray (terminals 1 to 18); color code CC10 	Pack of 10		6ES7193-6CP10-2MT0
PotDis-TB-P2-B, 18 potential terminals			
<ul style="list-style-type: none"> Blue (terminals 1 to 18); color code CC13 	Pack of 10		6ES7193-6CP13-2MT0
<ul style="list-style-type: none"> Gray (terminals 1 to 18); color code CC10 	Pack of 10		6ES7193-6CP10-2MT0

1.7 Accessories

Accessories, color identification labels (push-in terminals) PotDis	Packaging unit		Article number
PotDis-TB-BR-W, 18 potential terminals			
<ul style="list-style-type: none"> Yellow/green (terminals 1 to 18); color code CC11 	Pack of 10		6ES7193-6CP11-2MT0
<ul style="list-style-type: none"> Red (terminals 1 to 18); color code CC12 	Pack of 10		6ES7193-6CP12-2MT0
<ul style="list-style-type: none"> Blue (terminals 1 to 18); color code CC13 	Pack of 10		6ES7193-6CP13-2MT0
<ul style="list-style-type: none"> Gray (terminals 1 to 18); color code CC10 	Pack of 10		6ES7193-6CP10-2MT0
PotDis-TB-n.c.-G, 18 potential terminals			
<ul style="list-style-type: none"> Gray (terminals 1 to 18); color code CC10 	Pack of 10		6ES7193-6CP10-2MT0

Accessories for motor starter	Packaging unit	Article number
3DI / LC module	Pack of 1	3RK1908-1AA00-0BP0
Fan	Pack of 1	3RW4928-8VB00
Additional mechanical bracket for BaseUnit	Pack of 1	3RK1908-1EA00-1BP0
Cover for an empty BaseUnit	Pack of 1	3RK1908-1CA00-0BP0
Touch protection cover for infeed bus	Pack of 1	3RK1908-1DA00-2BP0

Supplements to ET 200SP documentation

2.1 System manual

System manual ET 200SP Distributed I/O system, Edition 02/2018

Section 10.2 Creating the control data record

For the configuration control (option handling) you can plug the following communication modules:

- CM DP
- CP 1542SP-1
- CP 1543SP-1
- CP 1542SP-1 IRC
- BusAdapter BA-Send 1xFC

For the communication modules listed above special slot rules apply for use with the ET 200SP CPUs applies:

If you plug the communication modules in the central configuration control as mentioned above (e.g. CM DP), then these modules cannot be influenced by the configuration control. You must therefore leave these modules in the slots preassigned in the station master and enter the slot numbers from the station master in the control data record ("Station option slot = Station master slot").

In a station option, all slots up to the module furthest from the CPU (see list above) must be present in the control data record.

Section 13.6 Firmware update

Modules with firmware version V0.0.0 do not support the "firmware update" function.

Section 15.5 Climatic ambient conditions

The following table shows the permissible climatic ambient conditions for the ET 200SP distributed I/O system:

Table 2- 1 Climatic ambient conditions

Ambient conditions	Permitted range	Comments
Temperature: Horizontal mounting position: Vertical mounting position:	From 0 °C to 60 °C From 0 °C to 50 °C	Information on extended temperature ranges are defined in the respective product data sheet.
Permitted temperature change	10 K/h	-
Relative humidity	From 10% to 95%	Without condensation or icing.
Air pressure	From 1140 hPa to 795 hPa	Corresponds to an altitude of -1000 m to 2000 m
Pollutant concentration	ANSI/ISA-71.04 severity level G1; G2; G3	-

SIPLUS products based on ET 200SP are offered for reliable operation under heavy to extreme operating conditions.

Using the distributed IO system ET 200SP over 2000 m above sea level.

The maximum "operating elevation in relation to sea level" depends on the module and is described in the technical specifications of the respective module.

For altitudes > 2000 m the following constraints apply for the maximum specified ambient temperature:

Restrictions of the maximum ambient temperature specified with regard to the operating altitude

Operating altitude	Derating factor for ambient temperature ¹⁾
-1000 m to 2000 m	1.0
2000 m to 3000 m	0.9
3000 m to 4000 m	0.8
4000 m to 5000 m	0.7

¹⁾ Base value for application of the derating factor is the maximum permissible ambient temperature in °C for 2000 m.

Note

- Linear interpolation between altitudes is permissible.
- The derating factors compensate for the decreasing cooling effect of air in higher altitudes due to lower density.
- Note the mounting position of the respective module in the technical specifications. The basis is the standard IEC 61131-2:2017.

Note

Power supplies

Make sure that the power supplies you use are rated for altitudes > 2000 m.

Details about certification on the components of the distributed I/O system ET 200SP

Fail-safe modules are certified for operation in safety mode up to the maximum altitude listed in the product data sheet (in accordance with IEC 61508-1: 2010, EN ISO 13849-1: 2015 and EN 62061:2005/ A2:2015).

All other markings and certifications are currently based on an altitude of up to 2000 m.

Effects on the availability of modules

The higher cosmic radiation present during operation at altitudes above 2000 m will also start to have an effect on the failure rate of electronic components (the so-called soft error rate). In rare cases this can result in a transition of the module into the safe state, especially for fail-safe modules. However, the functional safety of the module is fully retained.

2.2 BaseUnits manual

2.2.1 Special consideration for BaseUnits with functional versions < 04

The following BaseUnits with functional version < 04 can only be used in potential groups with rated voltages ≤ 48 V DC or 24 V AC:

- BaseUnit BU20-P12+A0+4B (6ES7193-6BP20-0BB1).
- BaseUnit BU20-P12+A0+0B (6ES7193-6BP00-0BD0).

2.2.2 Terminal labeling of the PotDis-TB

New specification of the terminal labeling

New specification offers the following advantages:

- Unique terminal numbering per slot, even though the same reference identifier is used for the PotDis-BU and the PotDis-TB of a slot.
- Best possible readability
- Shortest possible designation to keep the work for conductor labeling as low as possible
- Compliant with ECAD rules
- Complies with the previous ET 200SP Logic
- You can continue using the color identification label CC00

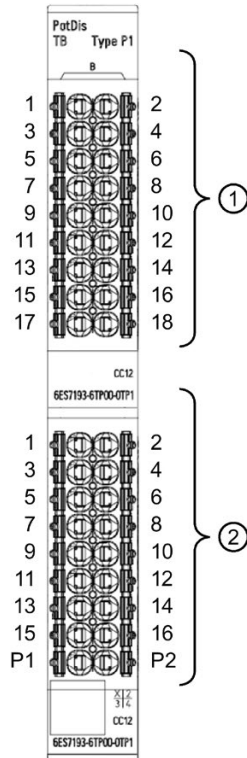

- ① **Terminal labeling of the PotDis-TB**
- ② **Terminal labeling of the PotDis-BU**

B1 to B18. To save space the preceding character "B" is printed once at the top and may not be covered by the color identification labels.

1 to 16, the supply terminals P1 and P2.

2.3 CPU manuals

Manual CPU 1512SP-1 PN, Edition 09/2016

Section 4.1 Status and error display of the CPU

MT1/MT2 LEDs on BusAdapter BA 2xSCRJ, BA SCRJ/RJ45, BA SCRJ/FC

Table 2- 2 Status and error displays of MT1/MT2 LEDs

LED	Meaning	Solution
MT1/MT2*		
□ Off	No error	---
■ On	<ul style="list-style-type: none"> Fiber-optic error Maintenance demanded: Attenuation through the fiber-optic cable is so high that operation will soon no longer be possible. 	Causes and measures for the transmission route: <ul style="list-style-type: none"> Replacement of fiber-optic cable if damaged or aged Correct installation of the PROFINET connector/PROFINET connections Adherence to maximum length of 50 m for POF cable or 100 m for PCF cable Secure fit of the FOC connector.

* Only available on BusAdapter BA 2xSCRJ

Section 6 Technical specifications

Technical specifications of the BusAdapters BA 2xSCRJ, BA SCRJ/RJ45, BA SCRJ/FC

The maximum length of the PCF-GI fiber-optic cable is 250 m.

Device manuals CPU 1510SP-1 PN and CPU 1512SP-1 PN, Edition 09/2016

"LED" instruction

You can read the status (e.g. "On" or "Off") of LEDs of a CPU or a module using the "LED" instruction. Note, however, that is not possible to read the LED status of the LINK RX/TX LEDs of the CPU 1510SP-1 PN and CPU 1512SP-1 PN.

You can find additional information on the "LED" instruction in the STEP 7 online help.

2.4 Interface module manuals

Configuration notes on interface modules depending on the I/O modules

Module	Firm-ware version	IM 155-6 PN BA	IM 155-6 PN ST					IM 155-6 PN HF IM 155-6 PN/2 HF V4.2 and higher IM 155-6 PN/3 HF V4.2 and higher							IM 155-6 PN HS	IM 155-DP HF				
		V3.2	V1.0	V1.1	V3.1	V3.3	V4.1	V2.0	V2.1	V2.2	V3.0	V3.1	V3.3	V4.2	V4.0	V1.0	V1.1	V3.0	V3.1	V4.2
AI 2xI 2-/4-wire ST	V1.0	✓	---	---	✓	✓	✓	---	---	---	✓	✓	✓	✓	✓	---	---	✓	✓	✓
AI 2xU ST	V1.0	✓	---	---	✓	✓	✓	---	---	---	✓	✓	✓	✓	✓	---	---	✓	✓	✓
AI 2xU/I 2-/4-wire HF	V2.0	✓	✓	✓	✓	✓	✓	✓	✓	✓	✓	✓	✓	✓	✓	✓	✓	✓	✓	✓
AI 8xI 2-/4-wire BA	V1.0	✓	---	✓	✓	✓	✓	---	---	✓	✓	✓	✓	✓	✓	---	✓	✓	✓	✓
AI 8xU BA	V1.0	✓	---	✓	✓	✓	✓	---	---	✓	✓	✓	✓	✓	✓	---	✓	✓	✓	✓
AI Energy Meter 400VA C ST	V3.0	✓	✓	✓	✓	✓	✓	✓	✓	✓	✓	✓	✓	✓	✓	✓	✓	✓	✓	✓
AI Energy Meter 480VA C ST	V4.0	✓	---	---	✓	✓	✓	---	---	---	✓	✓	✓	✓	✓	---	---	✓	✓	✓
AI Energy Meter 480VA C/CT HF	V6.0	✓	✓	✓	✓	✓	✓	✓	✓	✓	✓	✓	✓	✓	✓	✓	✓	✓	✓	✓
AI Energy Meter 480VA C/RC HF	V6.0	✓	✓	✓	✓	✓	✓	✓	✓	✓	✓	✓	✓	✓	✓	✓	✓	✓	✓	✓
AQ 2xI ST	V1.0	✓	---	---	✓	✓	✓	---	---	---	✓	✓	✓	✓	✓	---	---	✓	✓	✓
AQ 2xU ST	V1.0	✓	---	---	✓	✓	✓	---	---	---	✓	✓	✓	✓	✓	---	---	✓	✓	✓
DI 8x24VD C BA	V1.0	✓	---	✓	✓	✓	✓	---	---	✓	✓	✓	✓	✓	✓	---	✓	✓	✓	✓
DI 8x24VD C HS	V1.0	✓	---	✓	✓	✓	✓	---	---	✓	✓	✓	✓	✓	✓	---	✓	✓	✓	✓
DI 8x24VD C HF	V2.0	✓	✓	✓	✓	✓	✓	✓	✓	✓	✓	✓	✓	✓	✓	✓	✓	✓	✓	✓

Module	Firm-ware version	IM 155-6 PN BA	IM 155-6 PN ST					IM 155-6 PN HF IM 155-6 PN/2 HF V4.2 and higher IM 155-6 PN/3 HF V4.2 and higher							IM 155-6 PN HS	IM 155-DP HF				
		V3.2	V1.0	V1.1	V3.1	V3.3	V4.1	V2.0	V2.1	V2.2	V3.0	V3.1	V3.3	V4.2	V4.0	V1.0	V1.1	V3.0	V3.1	V4.2
DI 16x24V DC ST	V1.1	✓	✓	✓	✓	✓	✓	✓	✓	✓	✓	✓	✓	✓	✓	✓	✓	✓	✓	✓
DQ 4x24VD C/2A HS	V1.0	✓	---	✓	✓	✓	✓	---	---	✓	✓	✓	✓	✓	✓	---	✓	✓	✓	✓
DQ 4x24VD C/2A HF	V2.0	✓	✓	✓	✓	✓	✓	✓	✓	✓	✓	✓	✓	✓	✓	✓	✓	✓	✓	✓
DQ 4x24 ... 230VA C/2A HF	V1.0	✓	---	---	---	✓	✓	---	---	---	---	✓	✓	✓	✓	---	---	✓	✓	✓
RQ 4x120V DC- 230VA C/5A NO MA ST	V1.0	✓	---	---	✓	✓	✓	---	---	---	✓	✓	✓	✓	✓	---	---	✓	✓	✓
DQ 8x24VD C/0.5A HF	V2.0	✓	✓	✓	✓	✓	✓	✓	✓	✓	✓	✓	✓	✓	✓	✓	✓	✓	✓	✓
DQ 8x24VD C/0.5A BA	V1.0	✓	---	---	✓	✓	✓	---	---	---	✓	✓	✓	✓	✓	---	---	✓	✓	✓
DQ 16x24V DC/0.5 A BA	V0.0	✓	---	---	---	✓	✓	---	---	---	---	✓	✓	✓	✓	---	---	✓	✓	✓
DQ 16x24V DC/0.5 A ST	V1.1	✓	✓	✓	✓	✓	✓	✓	✓	✓	✓	✓	✓	✓	✓	✓	✓	✓	✓	✓
PotDis- TB-P1- R	-	✓	---	---	---	✓	✓	---	---	---	---	✓	✓	✓	✓	---	---	✓	✓	✓
PotDis- TB-P2- B	-	✓	---	---	---	✓	✓	---	---	---	---	✓	✓	✓	✓	---	---	✓	✓	✓
PotDis- TB-n.c.- G	-	✓	---	---	---	✓	✓	---	---	---	---	✓	✓	✓	✓	---	---	✓	✓	✓
PotDis- TB-BR- W	-	✓	---	---	---	✓	✓	---	---	---	---	✓	✓	✓	✓	---	---	✓	✓	✓

--- This combination is not permitted in the configuration

Compilation error with IM 155-6 PN HF as of V2.1, IM 155-6 PN HS V4.0

Affected components:

- IM 155-6 PN HF as of V2.1
- IM 155-6 PN HS V4.0

A compilation error can occur in isochronous mode of the ET200SP (IM 155-6 PN HF as of V2.1, IM 155-6 PN HS V4.0) with the setting "From OB" even if the settings are valid. The typical error message is: "The specific Ti value is invalid" or "The specific To value is invalid". But other error messages are possible as well.

Solution:

Upgrade the module description of the IM in this case. You can upgrade the module description of the IM in the network view or in the device view of the inspector window with the function "Update module description". The error can still occur with the current module description after the first compilation. If you have selected valid settings, the error will no longer occur with the subsequent compilation.

IM 155-6 PN ST Manual, Edition 04/2017

Response times

The response time of the IM 155-6 PN ST is made up of:

- Backplane bus cycle time
- Operating system processing

Note

Validity of the formula

The following formula applies to the ET 200SP backplane bus.

The formula does not apply to the ET-Connection bus.

Backplane bus cycle time

The backplane bus cycle time is the time the interface module requires to output new output data, read new input data and then copy the data to the PROFINET send buffer.

The backplane bus cycle time is the result of the update time configured for the interface module as IO device and amounts to at least 1 ms.

- If the configured update time ≥ 1 ms, the backplane bus cycle time is equal to the configured update time.
- If the configured update time < 1 ms, the backplane bus cycle time is the product of an integer multiple of the configured update time.

Table 2- 3 Example calculation

Configured update time	Backplane bus cycle time (integer multiple, minimum 1 ms)
250 μ s	4 x 250 μ s = 1000 μ s
750 μ s	2 x 750 μ s = 1500 μ s
1000 μ s	1000 μ s
2000 μ s	2000 μ s

Operating system processing time

The operating system processing time is calculated based on the following formula:

Operating system processing time output

Operating system processing time_output[μ s] = 147 + 3.775 number_m + 0.275 bytes_out

Operating system processing time input

Operating system processing time_input[μ s] = 158.3 + 2.325 number_m + 0.325 bytes_in

Explanation of the parameters:

Number_m: Total number of all modules (incl. server module)

Bytes_out: Sum of all output bytes

Bytes_in: Sum of all input bytes

Calculating the response time**Response time output**

The response time output of the IM 155-6 PN ST is made up of:

- Backplane bus cycle time
- Operating system processing time_output.

Response time input

The response time input of the IM 155-6 PN ST is made up of:

- Backplane bus cycle time
- Operating system processing time_input.

IM 155-6 PN HF manual, Edition 12/2015**Section 3.1 Pin assignment**

PROFINET interface X1 Port 2:

If autonegotiation is disabled, the RJ-45 socket (X1 Port 2) has the switch assignment (MDI-X).

IM 155-6 PN HS manual, Edition 09/2016

Section 3.1 Pin assignment

PROFINET interface X1 Port 2:

If autonegotiation is disabled, the RJ-45 socket (X1 Port 2) has the switch assignment (MDI-X).

Section 7 Technical specifications

- The PROFINET certification of network Class 3 is in preparation.
- Technical specifications of the BusAdapters BA 2×SCRJ, BA SCRJ/RJ45, BA SCRJ/FC:
The maximum length of the PCF-GI fiber-optic cable is 250 m.

2.5 I/O module manuals

Configuration notes on the I/O modules (supplement to Product overview section in the manual)

I/O module		Article number	Firmware version	STEP 7 (TIA Portal)	STEP 7 V5.5 SP3
Digital input modules	DI 16x24VDC ST	6ES7131-6BH00-0BA0	V1.1.0	HSP0162 V13 SP1 or higher	HSP0229 V6.0
	DI 8x24VDC BA	6ES7131-6BF00-0AA0	V1.0.0	HSP0126	HSP0229 V5.0
	DI 8x24VDC ST	6ES7131-6BF00-0BA0	V1.1.0	V13 Update 3	HSP0229 V4.0
	DI 8x24VDC HF	6ES7131-6BF00-0CA0	V2.0.0	HSP0163 V13 SP1 Update 4 or higher	HSP0229 V6.0
	DI 8x24VDC HS	6ES7131-6BF00-0DA0	V1.0.2	Integrated as of V14	HSP0229 V5.0
Digital output modules	DQ 8x24VDC/0.5A BA	6ES7132-6BF00-0AA1	V1.0.0	HSP0162 V13 SP1 or higher	HSP0230 V6.0
	DQ 4x24VDC/2A ST	6ES7132-6BD20-0BA0	V1.1.0	V13 Update 3	HSP0230 V4.0
	DQ 8x24VDC/0.5A ST	6ES7132-6BF00-0BA0	V1.1.0	V13 Update 3	HSP0230 V4.0
	DQ 16x24VDC/0.5A ST	6ES7132-6BH00-0BA0	V1.1.0	HSP0162 V13 SP1 or higher	HSP0230 V6.0
	DQ 8x24VDC/0.5A HF	6ES7132-6BF00-0CA0	V2.0.0	HSP0163 V13 SP1 Update 4 or higher	HSP0230 V6.0
	DQ 4x24VDC/2A HF	6ES7132-6BD20-0CA0	V2.0.0	HSP0163 V13 SP1 Update 4 or higher	HSP0230 V6.0
	DQ 4x24VDC/2A HS	6ES7132-6BD20-0DA0	V1.0.2	Integrated as of V14	HSP0230 V5.0
	DQ 4x24...230VAC/2A ST	6ES7132-6FD00-0BB1	V1.0	as of V13	HSP0230 V3.0
	DQ 4x24...230VAC/2A HF	6ES7132-6FD00-0CU0	V1.0.0	as of V14 with HSP0240	HSP 0230 as of V8.0
	RQ 4x120VDC-230VAC/5A NO ST	6ES7132-6HD00-0BB1	V1.0.0	HSP0128	HSP0232 V5.0
	RQ 4x120VDC-230VAC/5A NO MA ST	6ES7132-6MD00-0BB1	V1.0.0	HSP0162 V13 SP1 or higher	HSP0232 V6.0

I/O module		Article number	Firmware version	STEP 7 (TIA Portal)	STEP 7 V5.5 SP3
Analog input modules	AI 8xU BA	6ES7134-6FF00-0AA1	V1.0.0	HSP0126	HSP0227 V5.0
	AI 2xU ST	6ES7134-6FB00-0BA1	V1.0.0	HSP0160 V13 SP1 or higher	HSP0227 V6.0
	AI 8xI 2-/4-wire BA	6ES7134-6GF00AA1	V1.0.0	HSP0126	HSP0227 V5.0
	AI 4xI 2-/4-wire ST	6ES7134-6GD00-0BA1	V1.1.0	V13 Update 3	HSP0227 V4.0
	AI 2xI 2-/4-wire ST	6ES7134-6GB00-0BA1	V1.0.0	HSP0160 V13 SP1 or higher	HSP0227 V6.0
	AI 4xU/I 2-wire ST	6ES7134-6HD00-0BA1	V1.1.0	V13 Update 3	HSP0227 V4.0
	AI 2xU/I 2-/4-wire HF	6ES7134-6HB00-0CA1	V2.0.0	HSP0161 V13 SP1 or higher	HSP0227 V6.0 V5.5 SP4 HF7 or higher
	AI 2xU/I 2-/4-wire HS	6ES7134-6HB00-0DA1	V2.0.1	Integrated as of V14	HSP0227 V5.0
	AI Energy Meter 400VAC ST	6ES7134-6PA01-0BD0	V3.0.0	V13 SP1 Update 4 HSP0159	HSP0227 V6.0
	AI Energy Meter 480VAC ST	6ES7134-6PA20-0BD0	V4.0.0	V13 SP1 Update 4 HSP0159	HSP0227 V6.0 V5.5 SP4 HF7 or higher
	AI Energy Meter 480VAC/CT HF	6ES7134-6PA00-0CU0	V6.0.0	V15 or higher with HSP0253	V5.5 SP3 or higher
	AI Energy Meter 480VAC/RC HF	6ES7134-6PA20-0CU0	V6.0.0	V15 or higher with HSP0253	V5.5 SP3 or higher
	Analog output modules	AQ 2xU ST	6ES7135-6FB00-0BA1	V1.0.0	HSP0160 V13 SP1 or higher
AQ 2xI ST		6ES7135-6GB00-0BA1	V1.0.0	HSP0160 V13 SP1 or higher	HSP0228 V6.0
AQ 4xU/I ST		6ES7135-6HD00-0BA1	V1.1.0	V13 Update 3	HSP0228 V4.0
AQ 2xU/I HS		6ES7135-6HB00-0DA1	V2.0.1	Integrated as of V14	HSP0228 V5.0

2.5.1 Digital module device manuals

Manuals for I/O modules ST, BA

When you have deactivated all channels of the I/O module, a diagnostics alarm is still generated in the case of a fault if the "Missing supply voltage L+" diagnostics is enabled. For the following I/O modules, this behavior is corrected as of firmware version > V1.1.0:

- DI 16x24VDC ST
- DI 8x24VDC ST
- DQ 16x24VDC/0.5A ST
- DQ 8x24VDC/0.5 A ST
- DQ 4x24VDC/0.5A ST

Manuals for digital input modules with wire-break detection

When wire-break detection is configured the module requires a low quiescent current at the digital input in case of "0" signal for the monitoring. The parallel connection of a resistor with 25 kΩ to 45 kΩ is required in order that this quiescent current can flow when encoder contacts are open.

If wire-break detection is disabled in the configuration, no parallel connection of the resistor is required.

If wire-break detection is configured, connect a resistor with 25 kΩ to 45 kΩ parallel to each mechanical encoder contact.

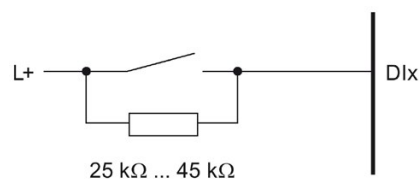

Figure 2-1 Connect mechanical encoder contact with resistor

Manuals DI 4x120...230VAC ST, Edition 02/2014; DQ 4x24...230VAC/2A ST, Edition 02/2014

Section 4.3 Address space

If you have enabled value status, the module returns value status 1, regardless of the state of the connected supply voltage.

Manual DI 8x24VDC HF, Edition 02/2014

Section 6.1 Technical specifications

- 24 V encoder supply
 - Output current, max.: 700 mA, total current

Manual DI 8xNAMUR HF, Edition 02/2014

Section A.2 Parameter assignment and structure of parameter data record

With data records 0 to 7, you can configure individual channels.

When the interface module IM 155-6 DP HF (PROFIBUS DP) is used and data records 0 and 1 are read, the module returns the diagnostics data records and not the parameter data records of the DI 8xNAMUR HF.

DQ 4x24VDC/2A HS manual, Edition 09/2016

Section 6.1 Technical specifications

For this module, the marine approval for the bridge and deck zone is valid from a bus cycle time of at least 250 μ s.

Manual DQ 4x24..230VAC/2A ST digital output module, Edition 03/2015

Section 3.1 Pin assignment; Supply voltage fuse protection

The module has neither short-circuit protection nor overload protection. Protect the module from being destroyed by impermissible high current and install a fine fuse in the supply line. The maximum rated current of the fine fuse depends on the hardware function status (FS) of the module.

HW functional status of the module	Max. rated current of fuse	Tripping characteristic
FS \leq 3	8 A	Quick response
FS \geq 4	10 A	Quick response

Section 6.1 Technical specifications, Switching frequency with inductive load

The switching frequency of the outputs with inductive loads is max. 0.5 Hz.

Higher switching frequency is possible in spite of this, and depends on the alternating voltage and switched inductors or the power factor of the electric motor used.

Alternating voltage	Condition	Max. switching frequency
200 VAC or lower	---	10 Hz
200 VAC or higher	<ul style="list-style-type: none"> Power factor of the electric motor $\cos \varphi > 0.35$ Electric motor must only be turned off after startup (no jogging mode). <p>Electric motors which are turned off during startup could create inductive shutoff voltages > 600 V, which could destroy the output electronics (Triac).</p>	10 Hz

DQ 8x24VDC/0.5A ST manual, Edition 07/2014

Section 4.2 Explanation of the parameters (as of functional version FS-05 of DQ 8x24VDC/0.5A ST)

Diagnostics: Wire break:

The module responds to a wire break as follows:

- Disabled:
 - Channel status LED lit green
 - Output voltage present at channel
- Enabled:
 - Channel status LED is off
 - Output is switched off
 - In addition, the wire break diagnostics is signaled and the DIAG LED on the module flashes red

Note

If one of the two parameters "Diagnostics: Short-circuit to L+" or "Diagnostics: Wire break" is enabled and one of these diagnostics occurs, the affected channel is switched off. This prevents undefined load switching and supports detection of a faulty channel for module diagnostics.

DQ 4x24...230VAC/2A HF Manual, Edition 02/2018

Section 3.1.1. und 4.1.1 Wiring and block diagram

The following figure shows an example for the terminal assignment of the digital output module DQ 4x24...230VAC/2A HF on the BaseUnit BU type U0 (3-wire connection) in combination with a potential distribution module and terminal block.

For a 3-wire connection you connect the protective earth (PE) of the actuator to the terminal block.

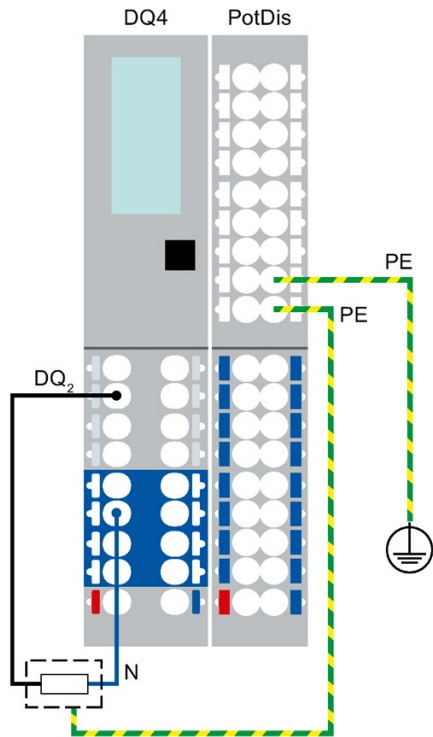

Figure 2-2 3-wire connection of actuators with potential distribution module at the digital output module DQ 4x24...230VAC/2A HF

RQ 4x120VDC-230VAC/5A NO ST manual, Edition 03/2015 and RQ 4x120VDC-230VAC/5A NO MA ST manual, Edition 12/2015

Section 3.1 Wiring and block diagram

The AUX terminals of the self-assembling voltage bus can be used for the connection of the protective conductor (PE) or for voltages up to a maximum of 24 V DC.

2.5.2 Analog module device manuals

Manuals for analog input modules

Manual	Edition
AI 8xI 2-/4-wire BA	03/2015
AI 8xU BA	03/2015
AI 2xU ST	12/2015
AI 4xI 2-wire 4..20mA HART	11/2014
AI 2xU/I 2-/4-wire HF	12/2015

Section 5.2 Parameters

Note

Please note that the settings in the "Interference frequency suppression" parameter have a direct effect on the cycle time of the module. The analog value is therefore also affected by additionally set filtering via the "Smoothing" parameter.

Manuals AI 2xU/I 2-/4-wire HF, Edition 12/2015; AI Energy Meter 480VAC ST, Edition 12/2015

For configuration with STEP 7 V13 or higher (TIA Portal), real values between -7×10^{28} and $+7 \times 10^{28}$ can be input. This is true for configuration via HSP and via GSD file (PROFINET).

For configuration with STEP 7 V5.5 SP4 as of HF7, configuration by means of GSD file (PROFINET) with REAL values of -1.175×10^{38} to $+3.402 \times 10^{38}$ is possible.

With STEP 7 SP4 to HF6, parameter assignment of REAL values is not possible. Functions that require REAL values are not available in this case.

AI Energy Meter 480VAC/CT HF, Edition 07/2018, and AI Energy Meter 480VAC/RC HF, Edition 07/2018 device manuals

Section A.2 Structure of the parameter data record 128 for the entire module

Module parameter block

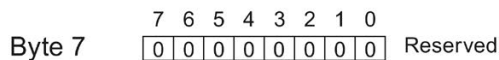
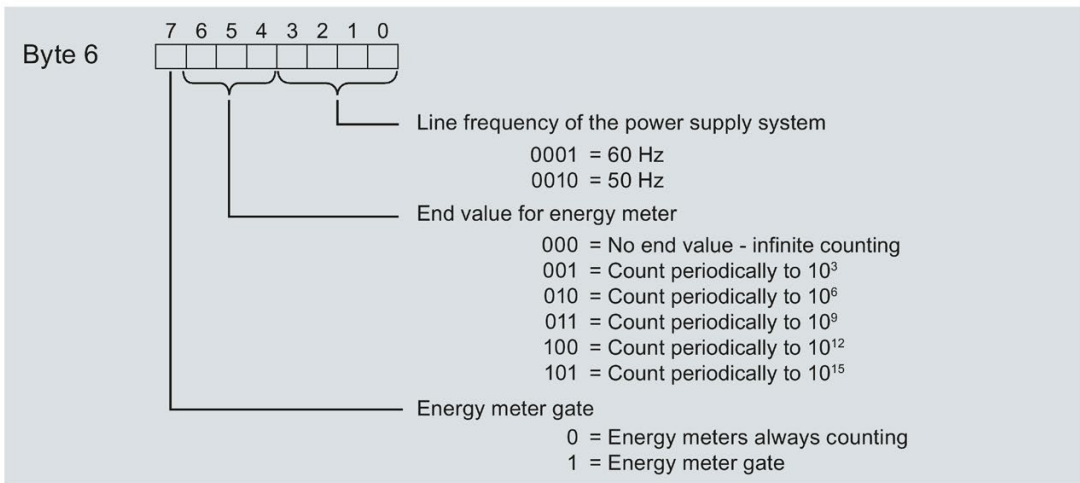
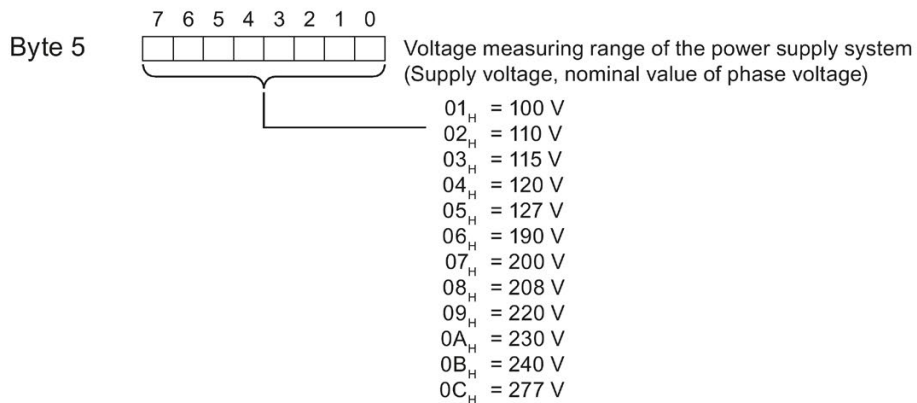
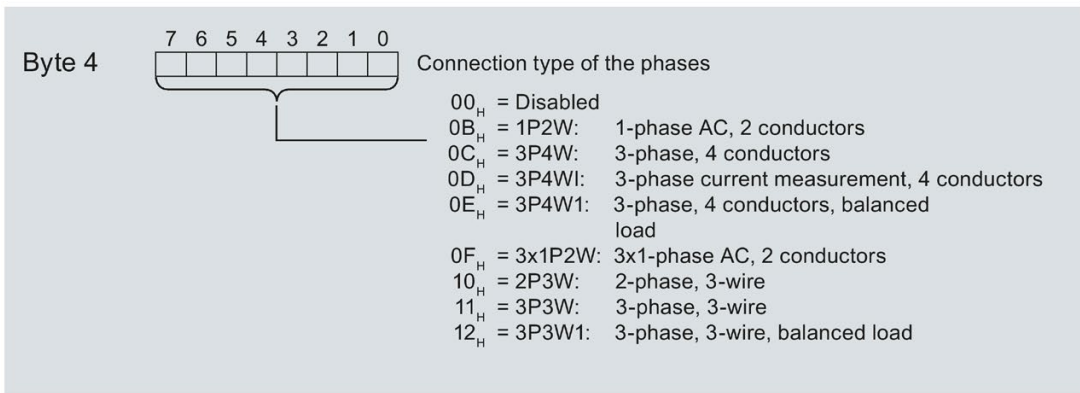

Section D.5 User data variants with 32 bytes input data / 20 bytes output data

Table D7 - Total energy L1L2L3 (ID249 or F9h)

Table 2- 4 Total energy L1L2L3

Byte	Allocation	Data type	Unit	Value range	Measured value ID
0	User data variant	BYTE	-	249 (F9h)	-
1	Quality information = QQ ₁ I ₃ U ₃ I ₂ U ₂ I ₁ U ₁	BYTE	Bit string	qq xx xx xx	-
2	Reserved	BYTE	-	-	-
3	Reserved	BYTE	-	-	-
4 ... 7	Total active energy inflow L1L2L3	UDINT	1 Wh	0 to 2147483647	220
8 ... 11	Total active energy outflow L1L2L3	UDINT	1 Wh	0 to 2147483647	221
11 ... 15	Total reactive energy inflow L1L2L3	UDINT	1 varh	0 to 2147483647	222
16 ... 19	Total reactive energy outflow L1L2L3	UDINT	1 varh	0 to 2147483647	223
20 ... 23	Total apparent energy L1L2L3	UDINT	1 VAh	0 to 2147483647	224
24	Reserved	BYTE	-	-	-
25	Scaling active energy, inflow	USINT	-	0 ... 255	-
26	Scaling active energy, outflow	USINT	-	0 ... 255	-
27	Scaling reactive energy, inflow	USINT	-	0 ... 255	-
28	Scaling reactive energy, outflow	USINT	-	0 ... 255	-
29	Scaling apparent energy	USINT	-	0 ... 255	-
30	Reserved	BYTE	-	-	-
31	Total power factor L1L2L3	USINT	0.01	0 ... 100	66037

Manuals AI Energy Meter 400VAC ST, Edition 12/2015; AI Energy Meter 480VAC ST, Edition 12/2015

Requirements for the operation of the AI Energy Meter on slot 1 of the ET 200SP:

Interface module / CPU	AI Energy Meter 400VAC ST (6ES7134-6PA01-0BD0)	AI Energy Meter 480VAC ST (6ES7134-6PA20-0BD0)
IM 155-6 PN BA (6ES7155-6AR00-0AN0)	Can be operated on slot 1 for all IM 155-6 PN BA	
IM 155-6 PN ST (6ES7155-6AU00-0BN0)	Can be operated on slot 1 for IM 155-6 PN ST from firmware version V3.1 and higher and functional status FS 07	
IM 155-6 PN HF (6ES7155-6AU00-0CN0)	Can be operated on slot 1 for IM 155-6 PN HF from firmware version V3.0 and higher and functional status FS 05	
IM 155-6 DP HF (6ES7 155-6BU00-0CN0)	Can be operated on slot 1 for IM 155-6 DP HF from firmware version V3.0 and higher	
CPU 1510SP-1 PN, CPU 1512SP-1 PN, CPU 1515SP PC	Can be operated on slot 1 for all CPUs	

In the manual for Energy Meter 480VAC ST, Edition 12/2015

In the device manual for Energy Meter 480VAC ST, the measured value ID and the associated measured variables for the complete performance are reversed. The correct association is shown in the table below:

Measured value ID	Measured variables	Unit
34	Total active power L1L2L3	W
35	Total reactive power L1L2L3	var
36	Total apparent power L1L2L3	VA
65	Max. total active power	W
66	Max. total reactive power	var
67	Max. total apparent power	VA
95	Min. total active power	W
96	Min. total reactive power	var
97	Min. total apparent power	VA

If you use the user-data mapping via data record DS 130, please note that the texts for the measured variables are also displayed incorrectly during configuration.

During configuration of the measured variables for the total active, reactive, and apparent power, select the following texts:

Desired measured variable for the user-data mapping	Text to select during configuration
Total active power L1L2L3	Total apparent power L1L2L3 (ID00034)
Total reactive power L1L2L3	Total active power L1L2L3 (ID00035)
Total apparent power L1L2L3	Total reactive power L1L2L3 (ID00036)
Max. total active power	Max. total apparent power (ID00065)
Max. total reactive power	Max. total active power (ID00066)
Max. total apparent power	Max. total reactive power (ID00067)
Min. total active power	Min. total apparent power (ID00095)
Min. total reactive power	Min. total active power (ID00096)
Min. total apparent power	Min. total reactive power (ID00097)

The project configuration modification described above is no longer required if the following tools and GSD files are used:

- STEP 7 (TIA Portal) as of V14
- STEP 7 (TIA Portal) as of V5.5 SP4 with HSP 0227
- GSD file GSDML-V2.32-ET200SP-20160706

Manual for AQ 2xU/I HF, Edition 02/2014

Section 3.1 Wiring and block diagram, pin assignment

You can now also use the 3-wire connection in addition to the 2-wire and 4-wire connection for the analog module AQ 2xU/I HF.

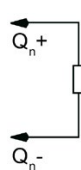
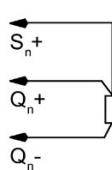
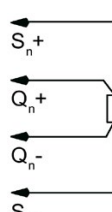
Pin assignment for AQ 2xU/I HF			Explanation
Voltage 2-wire connection 	Voltage 3-wire connection 	Voltage 4-wire connection 	<ul style="list-style-type: none"> • Qn+: Analog output voltage/current (positive), channel n • Qn-: Analog output voltage/current (negative), channel n • Sn+: Sensor line positive, channel n • Sn-: Sensor line negative, channel n

The 3-wire connection and 4-wire connection make compensation for line impedance possible. The compensation is not possible for 2-wire connections due to the missing sensor cable.

2.5.3 Communications module manuals

Communications module CM DP, Edition 12/2014

The communications module CM DP supports the PROFIsafe protocol V2.

Exception: Fail-safe modules that only support PROFIsafe V1 mode.

Communications module IO-Link Master CM 4xIO-Link, Edition 10/2017

Section Connecting, Wiring and block diagram

Connection: 2-wire and 3-wire connection in DQ operating mode:

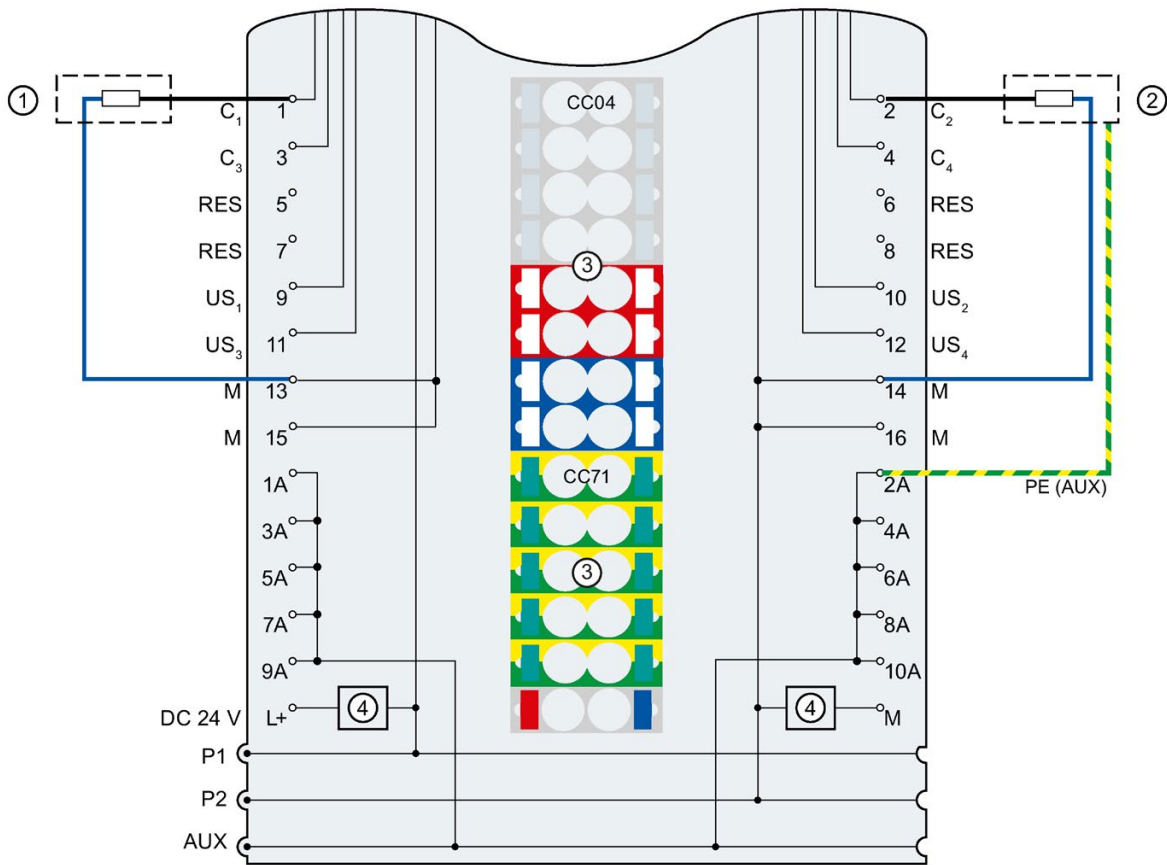

①	2-wire connection	1 A to 10 A	AUX terminals
②	3-wire connection	PE (AUX)	Protective conductor connection
③	Color-coded labels with color code CC04 and CC71 (optional)	P1, P2, AUX	Internal self-assembling voltage buses Connection to the left (dark-colored BaseUnit) Connection to the left interrupted (light-colored BaseUnit)
④	Filter connection supply voltage (only when light-colored BaseUnit is present)	C _n	Communication signal, DI, DQ
24 V DC	Supply voltage L+ (infeed for light-colored BaseUnit only)	RES	Reserved, must not be assigned
M	Ground	US _n	Supply voltage (positive)

Figure 2-3 Terminal assignment for 2-wire and 3-wire connection in DQ operating mode

2.5.4 Device manuals Technology modules

Technology module TM Pulse 2x24V, Edition 09/2015

Supplement in the section Preface

Please read the information about Open Source Software on the Internet
(<https://support.industry.siemens.com/cs/ww/en/view/109740777>).