



# HPS Titan™ Series Encapsulated Transformers for Hazardous Locations

# HPS Titan Series

## Encapsulated Transformers

HPS Titan series encapsulated transformers offer an innovative design with technological improvements for industrial and hazardous applications.

The transformer core and coil is completely encapsulated in epoxy and silica, providing excellent protection from airborne contaminants and prevents the ingress of moisture.

HPS Titan series three phase design has a removable hinged door and factory installed grounding lugs, reducing installation time and money.



### APPLICATIONS



Petrochemical



Marine



Industrial



Oil & Gas



Mining



Wastewater

### APPROVALS

- ANSI/ISA 12.12.10 - File No. E258346 (Class 1, Division 2, Groups A, B, C, D and Class 1, Zone 2, Group IIC, T3 Hazardous Locations) - T3C/T3A Temperature Classification
- UL 5085-1 and UL5085-2 Listed - File No. E258346
- ABS Type Approval (Marine Duty Service and Offshore Applications)

Titan X only:

CE Ex II 3G  
DEMKO 21 ATEX 2235X  
IECEX UL 21.0116X  
EX ec IIC t3 Gc

UK  
CA  
UL21UKEX2340X

### FEATURES & BENEFITS

#### Single Phase

- Copper winding
- Electrostatic shield
- Standard wall mounting with keyhole mounting slots
- Front accessible hinged door
- Standard Type 3R enclosure suitable for indoor or outdoor applications

#### Three Phase

- Higher impedance designs lower inrush and short circuit currents, allowing the use of less costly protective devices
- Completely encapsulated in epoxy and silica to prevent the ingress of moisture
- Standard 10kV BIL rating provides increased reliability and protection against critical equipment failure (including voltage spikes and other line transients)
- Copper winding
- Electrostatic shield
- Improved efficiency level that reduces energy costs
- Standard Type 4 enclosure suitable for indoor or outdoor applications
- Removable hinged door allows for easy access to terminations
- Standard integral floor and wall mounting brackets on select kVA's for faster installation
- Optional breather drains ensure that any moisture build-up due to condensation is easily eliminated without compromising Type 4/12 enclosure integrity (standard for HPS Titan X)

#### Temperature Code\* - Titan N:

- Class 1, Zone 2, Group IIC, T3
- T3A (115°C rise units) at 40°C ambient
- T3C (80°C & 95°C rise units) at 40°C ambient
- **80°C and 95°C rise units are suitable for 50°C ambient**  
80°C rise at 50°C ambient maintains T3C performance  
95°C rise at 50°C ambient maintains T3A performance  
(95°C rise unit only available in three phase)

\*For three phase units only

## Installation made fast & easy!

The improved three phase enclosure design allows for quick and easy installation. By simply loosening the screw clips on the side of the enclosure, installers are able to access the terminations. The removable hinged door and front accessible terminations allow for easier cable installation in confined spaces.



## Testing

All HPS transformers are tested at HPS prior to shipment. They must meet very stringent quality criteria prior to release.



### Three Phase

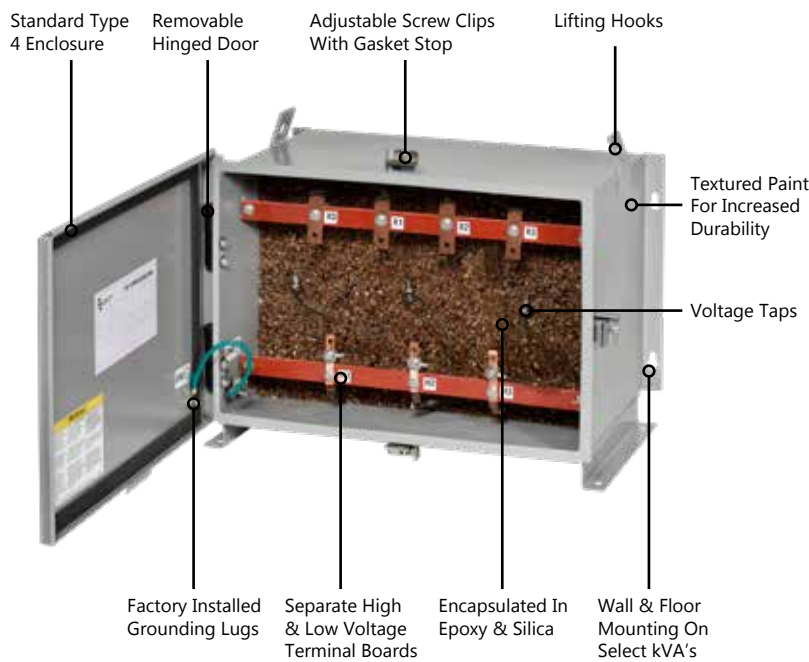

### Single Phase

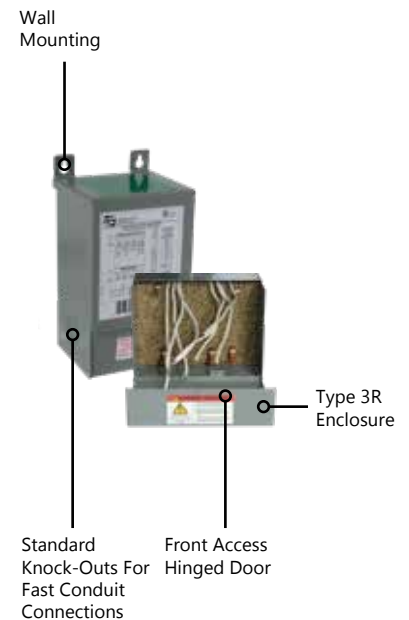

Easy access to ground\*



Removable hinged door\*



Quick access to terminations\*

\*On three phase units

# Specifications & Accessories



## SINGLE PHASE STANDARD SPECIFICATIONS

<b>kVA:</b>	Up to 37.5kVA	<b>Termination:</b>	Front accessible separated high and low voltage lead wires or copper tabs
<b>UL Listed:</b>	File: E258346	<b>Conduit Entry:</b>	Rear or side entry
<b>Frequency:</b>	60 Hz (50/60Hz options available)	<b>Impedance:</b>	Typically 1% to 7%
<b>Insulation System:</b>	130°C (80°C rise) up to 1 kVA 180°C (115°C rise) 1.5 to 37.5 kVA Optional 180°C (80°C rise) 1.5 to 37.5 kVA	<b>Mounting:</b>	Standard wall mounting with keyhole mounting slots. Lifting provisions standard from 5 kVA to 37.5 kVA.
<b>Enclosure Type:</b>	Heavy duty enclosed Type 3R standard [Optional Type 4, 12, 4X]	<b>Seismic:</b>	Seismically qualified according to the International Building Code (IBC) 2018, and the American Society of Civil Engineers ASCE 7-10 specifications, with the following design parameters: Spectral acceleration: $S_{DS} \leq 2.0$ g Importance factor: $I_p = 1.5$ Attachment/height ratio: $z/h = 1.0$ " OSHDP California Certified
<b>Enclosure Finish:</b>	ANSI 61 Grey	<b>Sound Level:</b>	Meets NEMA ST-20 standards (Optional low noise units available)
<b>Standard Primary Taps:</b>	Refer to wiring diagrams for details	<b>Warranty:</b>	10 years



## THREE PHASE STANDARD SPECIFICATIONS

### HPS Titan N

<b>kVA:</b>	Up to 150kVA
<b>Frequency:</b>	60 Hz or 50/60 Hz
<b>Insulation System:</b>	80°C rise (130°C class) - 2 & 3 kVA only 115°C rise (180°C class) Optional 80°C & 95°C (180°C class)
<b>Enclosure Type:</b>	Heavy duty enclosed Type 4 standard (also meets Type 12) [Optional Type 4X]
<b>Condensate Valve:</b>	None Valve recommended for environments where condensation may be present
<b>Optional Accessories:</b>	Glass filled Nylon condensate valve Part number: PLG19000
<b>UL Listed:</b>	File: E258346

### HPS Titan X

<b>kVA:</b>	6-75kVA
<b>Frequency:</b>	60 Hz or 50/60 Hz
<b>Insulation System:</b>	115°C rise (180°C class) Optional 80°C (180°C class)
<b>Enclosure Type:</b>	IP66 (optional IP66X)
<b>Condensate Valve:</b>	Glass filled Nylon
<b>Optional Accessories (Factory Installed):</b>	Stainless steel condensate valve
<b>IECEx Certified:</b>	IECEx UL 20.0021X
<b>ATEX:</b>	DEMKO 20 ATEX 2235X
<b>UKCA:</b>	UL21UKEX2340X

### Available for HPS Titan N and HPS Titan X

<b>Enclosure Finish:</b>	ANSI 61 Gray, UL50E textured powdered coating or stainless steels
<b>BIL Rating:</b>	10kV
<b>Neutral:</b>	Neutral Terminal for field connection (on applicable units)
<b>Standard Primary Taps:</b>	Refer to wiring diagram for details
<b>Termination:</b>	Front accessible separate high and low voltage terminals on select units
<b>Conduit Entry:</b>	Side or bottom enclosure entry (exceptions apply on bottom entry)
<b>Impedance:</b>	Typically 1.8% to 6.5%
<b>Mounting:</b>	Floor or wall/ceiling mounting available (refer to selection tables for details)
<b>Seismic:</b>	Seismically qualified according to the International Building Code (IBC) 2018, and the American Society of Civil Engineers ASCE 7-10 specifications, with the following design parameters: Spectral acceleration: $S_{DS} \leq 2.0$ g Importance factor: $I_p = 1.5$ Attachment/height ratio: $z/h = 1.0$ " OSHPD California Certified
<b>Sound Level:</b>	Meets NEMA ST-20 standards
<b>Warranty:</b>	10 years

# Part Numbering Guide

## HPS Titan Single Phase Part Numbering Guide

Family	kVA			Primary Voltage	Secondary Voltage	Winding Material/ Electrostatic Shield	Temp. Rise & Insul. Class	Enclosure
	Q	0	0					
<b>Family:</b> Q - Titan 1PH	<b>kVA Rating:</b> 0.5 kVA - C50 0.75 kVA - C75 1.5 kVA - 1C5 2 kVA - 002 3 kVA - 003 5 kVA - 005 7.5 kVA - 007 10 kVA - 010 15 kVA - 015 25 kVA - 025 37.5 kVA - 037 50 kVA - 050			<b>Primary Voltage:</b> 1PH L - 240x480 J - 347/380 P - 600 Y - 208/240/277 X - Export  <b>Secondary Voltage:</b> 1PH E - 120/240		<b>Winding Material:</b> C - Copper - 500VA K - CU + Shield - above 500VA  <b>Temperature Rise &amp; Insulation Class</b> B - 80°C <sup>1,3</sup> F - 115°C <sup>2</sup>  <b>Enclosure:</b> 3 - Type 3R* 4 - Type 4 6 - Type 4X (304SS) 7 - Type 4X (316SS) 5 - Type 12		



\*Default options - ignore if all following characters are default values

<sup>1</sup> 80°C rise is standard on units up to and including 1kVA (130°C insulation class, T3C temperature code)

<sup>2</sup> 115°C rise is standard on units 1.5kVA and above (180°C insulation class, T3C temperature code)

<sup>3</sup> 80°C rise is optional on units 1.5kVA and above (180°C insulation class, T3C temperature code)

## HPS Titan N Three Phase Part Numbering Guide

Family	Appl. Type	Generation	Phase	kVA				Primary Voltage	Secondary Voltage	Winding Material/ Electrostatic Shield	Temp. Rise & Insul. Class	Frequency	Enclosure		
				T	N	2	A							0	0
<b>Family:</b> T - Titan	<b>Type:</b> N - Hazardous Location (cULus & ABS Approval)	<b>Generation:</b> 2 - Current designs	<b>Phase (Pri-Sec):</b> A - 3PH Delta-Wye-N B - 3PH Wye-N-Delta C - 3PH Delta-Delta/CT D - 3PH Delta-Delta	<b>kVA Rating:</b> Titan N: 2kVA to 150kVA  2 kVA - 0002 3 kVA - 0003 6 kVA - 0006 9 kVA - 0009 15 kVA - 0015 30 kVA - 0030 45 kVA - 0045 75 kVA - 0075 112.5 kVA - 0112 150 kVA - 0150				<b>Primary Voltage:</b> 3PH G - 380D <sup>1</sup> H - 400D <sup>1</sup> J - 415V <sup>1</sup> K - 480D P - 600D, 600Y Q - 600D, 480D		<b>Secondary Voltage:</b> 3PH B - 208Y/120 C - 230Y/133 D - 240D, 240Y/139, or 240D/120CT G - 380Y/220 H - 400Y/231 K - 480Y/277 P - 600Y/347		<b>Winding Material:</b> K - CU + Shield  <b>Temperature Rise</b> A - 80°C Rise (130°C Class) B - 80°C Rise (180°C Class) C - 95°C Rise (180°C Class) F - 115°C Rise (180°C Class)		<b>Frequency:</b> 5 - 50/60Hz 6 - 60Hz*  <b>Enclosure:</b> F - Type 4* <sup>2</sup> G - Type 4X (304SS) H - Type 4X (316SS)	



<sup>1</sup>Units with primary voltage code "G", "H" & "J" come standard as 50/60Hz and are CE marked. All others are 60Hz by default

\*Default Options - ignore if all following characters are Default values (applicable to type N only)

<sup>2</sup>Type 4 enclosure is also Type 12

<sup>3</sup>Units with primary voltage code "U" only available with type X transformer and come standard as 50/60Hz

## HPS Titan X Three Phase Part Number Guide

Family	Appl. Type	Generation	Phase	kVA				Primary Voltage	Secondary Voltage	Winding Material/ Electrostatic Shield	Temp. Rise & Insul. Class	Frequency	Enclosure	
				0	0	4	5							
T	X	2	A	0	0	4	5	K	B	K	B	6	H	
<b>Family:</b> T - Titan				<b>kVA<sup>3</sup>:</b> Titan X: 6kVa to 75kVA 6 kVA - 0006 9 kVA - 0009 15 kVA - 0015 30 kVA - 0030 45 kVA - 0045 75 kVA - 0075				<b>Primary Voltage<sup>3</sup>:</b> 3PH G - 380D <sup>1</sup> H - 400D <sup>1</sup> J - 415V <sup>1</sup> K - 480D P - 600D, 600Y Q - 600D, 480D U - 690D			<b>Winding Material:</b> K - CU + Shield		<b>Frequency:</b> 5 - 50/60Hz 6 - 60Hz*	
<b>Type:</b> X - Hazardous Location (IECEX & ATEX & ABS Approval)								<b>Temperature Rise</b> B - 80°C Rise (180°C Class) F - 115°C Rise (180°C Class)			<b>Enclosure (IP66/IP66X):</b> F - Type 4* <sup>2</sup> G - Type 4X (304SS) H - Type 4X (316SS)			
<b>Generation:</b> 2 - Current designs								<b>Secondary Voltage<sup>3</sup>:</b> 3PH B - 208Y/120 C - 230Y/133 D - 240D, 240Y/139, or 240D/120CT G - 380Y/220 H - 400Y/231 K - 480Y/277 P - 600Y/347 U - 690Y/400						
<b>Phase (Pri-Sec):</b> A - 3PH Delta-Wye-N B - 3PH Wye-N-Delta C - 3PH Delta-Delta/CT D - 3PH Delta-Delta														

<sup>1</sup>Units with primary voltage code "G", "H", "J" & "U" come standard as 50/60Hz. All others are 60Hz by default  
<sup>2</sup>Default Options  
<sup>3</sup>Type 4 enclosure is also Type 12  
<sup>3</sup>kVA's and/or voltage outside of the scope of standard offering listed are available, however they must fall within the range of 60kVA - 75kVA and/or 208D/Y-690D/Y respectively

### ADVANTAGES OF IECEX CERTIFICATION\*

(Available with HPS Titan X)



There is an increasing need for installation efficiency and safety in industrial automation and hazardous locations. Equipment, especially electrical, and their use in these areas are covered by a wide range of IEC Standards and are generally highly regulated.

The use of the IECEX Conformity Assessment System and its Schemes offer some key advantages:

**Enhanced Safety**



Equipment, installations and systems are manufactured, operated and maintained in compliance with IEC International Standards.

**Simple Online verifications**



All issued IECEX Certificates are available for verification on [www.iecex.com](http://www.iecex.com) or on the IECEX app.

**UN endorsement**



The United Nations, via UNECE, has endorsed IECEX as the internationally-recognized certification system for promoting the improved safety of equipment, services and personnel associated with devices, systems and installations used in Ex areas.

**Cost Reductions**



IECEX certification reduces the need for additional testing and certification which can lower costs and streamline processes.

\*Source: <https://www.iecex.com/assets/Uploads/IECEX-brochure-LR-16.pdf>

# Selection Tables

HPS Titan  
Encapsulated Transformer

## COPPER WOUND, SINGLE PHASE

\*208/240/277 Primary Volts

120/240 Secondary Volts



60 Hz

kVA	Catalog Number	Case Style	Approx. Dimensions Inches [mm]			°C Temp. Rise	Approx. Weight Lbs. [kg]	Mtg Type W - Wall F - Floor	Wiring Diagram
			Width	Depth	Height				
0.5	QC50YECB	NQ2	5.06 [128.53]	4.56 [115.83]	9.30 [236.22]	80	19 [9]	W	SCD 3.1
0.75	QC75YECB	NQ2	5.06 [128.53]	4.56 [115.83]	9.30 [236.22]	80	21 [10]	W	SCD 3.1
1	Q1C0YEKB	NQ3	5.88 [149.36]	5.19 [131.83]	10.56 [268.23]	80	28 [13]	W	SCD 3.1
1.5	Q1C5YEKF	NQ3	5.88 [149.36]	5.19 [131.83]	10.56 [268.23]	115	36 [16]	W	SCD 3.1
2	Q002YEKF	NQ4	7.06 [179.33]	6.25 [158.75]	11.75 [298.45]	115	44 [19.8]	W	SCD 3.1
3	Q003YEKF	NQ4	7.06 [179.33]	6.25 [158.75]	11.75 [298.45]	115	56 [25.2]	W	SCD 3.1
5	Q005YEKF	NQ5	10.00 [254.00]	7.75 [196.85]	17.25 [438.15]	115	134 [61]	W	SCD 3.1
7.5	Q007YEKF	NQ5	10.00 [254.00]	7.75 [196.85]	17.25 [438.15]	115	160 [72]	W	SCD 3.1
10	Q010YEKF	NQ6	12.25 [311.15]	9.25 [234.95]	20.88 [530.36]	115	204 [92]	W	SCD 3.1
15	Q015YEKF	NQ6	12.25 [311.15]	9.25 [234.95]	20.88 [530.36]	115	248 [112]	W	SCD 3.1
25	Q025YEKF	NQ7	14.50 [368.30]	10.75 [273.05]	21.38 [543.06]	115	345 [156]	W	SCD 3.1
37.5	Q037YEKF	NQ8	14.50 [368.30]	10.75 [273.05]	27.38 [695.46]	115	476 [215]	W	SCD 3.1

\*347/380 Primary Volts

120/240 Secondary Volts



50/60 Hz

kVA	Catalog Number	Case Style	Approx. Dimensions Inches [mm]			°C Temp. Rise	Approx. Weight Lbs. [kg]	Mtg Type W - Wall F - Floor	Wiring Diagram
			Width	Depth	Height				
0.5	QC50FECB	NQ2	5.06 [128.53]	4.56 [115.83]	9.30 [236.22]	80	19 [8.6]	W	SCD 5.1
0.75	QC75FEKB	NQ2	5.06 [128.53]	4.56 [115.83]	9.30 [236.22]	80	21 [9.5]	W	SCD 5.1
1	Q1C0FEKB	NQ3	5.88 [149.36]	5.19 [131.83]	10.56 [268.23]	80	28 [12.6]	W	SCD 5.1
1.5	Q1C5FEKF	NQ3	5.88 [149.36]	5.19 [131.83]	10.56 [268.23]	115	36 [16.2]	W	SCD 5.1
2	Q002FEKF	NQ4	7.06 [179.33]	6.25 [158.75]	11.75 [298.45]	115	44 [19.8]	W	SCD 5.1
3	Q003FEKF	NQ5	7.06 [179.33]	6.25 [158.75]	11.75 [298.45]	115	56 [25.2]	W	SCD 5.1
5	Q005FEKF	NQ5	10.00 [254.00]	7.75 [196.85]	17.25 [438.15]	115	134 [61]	W	SCD 5.1
7.5	Q007FEKF	NQ6	10.00 [254.00]	7.75 [196.85]	17.25 [438.15]	115	160 [72]	W	SCD 5.1
10	Q010FEKF	NQ6	12.25 [311.15]	9.25 [234.95]	20.88 [530.36]	115	204 [92]	W	SCD 5.1
15	Q015FEKF	NQ6	12.25 [311.15]	9.25 [234.95]	20.88 [530.36]	115	248 [112]	W	SCD 5.1
25	Q025FEKF	NQ7	14.50 [368.30]	10.75 [273.05]	21.38 [543.06]	115	345 [156]	W	SCD 5.1
37.5	Q037FEKF	NQ8	14.50 [368.30]	10.75 [273.05]	27.38 [695.46]	115	476 [215]	W	SCD 5.1

\*240 X 480 Primary Volts

120/240 Secondary Volts

60 Hz

kVA	Catalog Number	Case Style	Approx. Dimensions Inches [mm]			°C Temp. Rise	Approx. Weight Lbs. [kg]	Mtg Type W - Wall F - Floor	Wiring Diagram
			Width	Depth	Height				
0.5	QC50LECB	NQ2	5.06 [128.53]	4.56 [115.83]	9.30 [236.22]	80	23 [10.4]	W	SCD 1.1
0.75	QC75LEKB	NQ2	5.06 [128.53]	4.56 [115.83]	9.30 [236.22]	80	24 [10.8]	W	SCD 1.1
1	Q1C0LEKB	NQ3	5.88 [149.36]	5.19 [131.83]	10.56 [268.23]	80	28 [12.6]	W	SCD 1.1
1.5	Q1C5LEKF	NQ3	5.88 [149.36]	5.19 [131.83]	10.56 [268.23]	115	35 [15.8]	W	SCD 1.1
2	Q002LEKF	NQ4	7.06 [179.33]	6.25 [158.75]	11.75 [298.45]	115	47 [21.2]	W	SCD 1.1
3	Q003LEKF	NQ4	7.06 [179.33]	6.25 [158.75]	11.75 [298.45]	115	62 [27.9]	W	SCD 1.1
5	Q005LEKF	NQ5	10.00 [254.00]	7.75 [196.85]	17.25 [438.15]	115	131 [59.0]	W	SCD 1.1
7.5	Q007LEKF	NQ5	10.00 [254.00]	7.75 [196.85]	17.25 [438.15]	115	155 [69.8]	W	SCD 1.1
10	Q010LEKF	NQ6	12.25 [311.15]	9.25 [234.95]	20.88 [530.36]	115	220 [99.0]	W	SCD 1.1
15	Q015LEKF	NQ6	12.25 [311.15]	9.25 [234.95]	20.88 [530.36]	115	248 [112]	W	SCD 1.1
25	Q025LEKF	NQ7	14.50 [368.30]	10.75 [273.05]	21.38 [543.06]	115	345 [156]	W	SCD 1.1
37.5	Q037LEKF	NQ8	14.50 [368.30]	10.75 [273.05]	27.38 [695.46]	115	476 [215]	W	SCD 1.1



# Selection Tables

HPS Titan  
Encapsulated Transformer



## COPPER WOUND, SINGLE PHASE

\*600 Primary Volts

120/240 Secondary Volts



60 Hz

kVA	Catalog Number	Case Style	Approx. Dimensions Inches [mm]			°C Temp. Rise	Approx. Weight Lbs. [kg]	Mtg Type W - Wall F - Floor	Wiring Diagram
			Width	Depth	Height				
0.5	QC50PECB	NQ2	5.06 [128.53]	4.56 [115.83]	9.30 [236.22]	80	15 [6.8]	W	SCD 2.1
0.75	QC75PEKB	NQ2	5.06 [128.53]	4.56 [115.83]	9.30 [236.22]	80	18 [8.1]	W	SCD 2.1
1	Q1C0PEKB	NQ3	5.88 [149.36]	5.19 [131.83]	10.56 [268.23]	80	27 [12.2]	W	SCD 2.1
1.5	Q1C5PEKF	NQ3	5.88 [149.36]	5.19 [131.83]	10.56 [268.23]	115	31 [14.0]	W	SCD 2.1
2	Q002PEKF	NQ4	7.06 [179.33]	6.25 [158.75]	11.75 [298.45]	115	40 [18.0]	W	SCD 2.1
3	Q003PEKF	NQ4	7.06 [179.33]	6.25 [158.75]	11.75 [298.45]	115	52 [23.4]	W	SCD 2.1
5	Q005PEKF	NQ5	10.00 [254.00]	7.75 [196.85]	17.25 [438.15]	115	114 [51.3]	W	SCD 2.1
7.5	Q007PEKF	NQ5	10.00 [254.00]	7.75 [196.85]	17.25 [438.15]	115	129 [58.1]	W	SCD 2.1
10	Q010PEKF	NQ6	12.25 [311.15]	9.25 [234.95]	20.88 [530.36]	115	197 [88.7]	W	SCD 2.1
15	Q015PEKF	NQ6	12.25 [311.15]	9.25 [234.95]	20.88 [530.36]	115	234 [106]	W	SCD 2.1
25	Q025PEKF	NQ7	14.50 [368.30]	10.75 [273.05]	21.38 [543.06]	115	285 [129]	W	SCD 2.1
37.5	Q037PEKF	NQ8	14.50 [368.30]	10.75 [273.05]	27.38 [695.46]	115	454 [205]	W	SCD 2.1

\*Export<sup>1</sup> Primary Volts

120/240 Secondary Volts



50/60 Hz

kVA	Catalog Number	Case Style	Approx. Dimensions Inches [mm]			°C Temp. Rise	Approx. Weight Lbs. [kg]	Mtg Type W - Wall F - Floor	Wiring Diagram
			Width	Depth	Height				
0.5	QC50XECB	NQ2	5.06 [128.53]	4.56 [115.83]	9.30 [236.22]	80	15 [6.8]	W	SCD 4.1
0.75	QC75XEKB	NQ2	5.06 [128.53]	4.56 [115.83]	9.30 [236.22]	80	20 [9.0]	W	SCD 4.1
1	Q1C0XEKB	NQ3	5.88 [149.36]	5.19 [131.83]	10.56 [268.23]	80	32 [14.4]	W	SCD 4.1
1.5	Q1C5XEKF	NQ3	5.88 [149.36]	5.19 [131.83]	10.56 [268.23]	115	35 [15.8]	W	SCD 4.1
2	Q002XEKF	NQ4	7.06 [179.33]	6.25 [158.75]	11.75 [298.45]	115	54 [24.3]	W	SCD 4.1
3	Q003XEKF	NQ5	10.00 [254.00]	7.75 [196.85]	17.25 [438.15]	115	105 [47.3]	W	SCD 4.1
5	Q005XEKF	NQ5	10.00 [254.00]	7.75 [196.85]	17.25 [438.15]	115	138 [62.1]	W	SCD 4.1
7.5	Q007XEKF	NQ6	12.25 [311.15]	9.25 [234.95]	20.88 [530.36]	115	189 [85.1]	W	SCD 4.1
10	Q010XEKF	NQ6	12.25 [311.15]	9.25 [234.95]	20.88 [530.36]	115	222 [99.9]	W	SCD 4.1
15	Q015XEKF	NQ7	14.50 [368.30]	10.75 [273.05]	21.38 [543.06]	115	300 [135]	W	SCD 4.1
25	Q025XEKF					Consult HPS			
37.5	Q037XEKF					Consult HPS			

<sup>1</sup>Export = 190/200/208/220/240<sup>2</sup> X 380/400/415/440/480<sup>2</sup> Primary Volts

<sup>2</sup>The primary voltage ratio of 240 or 480 is available at 60Hz only with secondary voltage of approximately 130/262V.

**\*Single Phase Notes:**

Units ending with letter "B" are 80°C rise

Units ending with letter "F" are 115°C rise; 80°C rise optional replace end suffix "F" with "B"

80°C rise units are T3C; 115°C rise units are T3A.

For shielded units 0.50kVA, replace the suffix "CB" with a "KB"

Refer to wiring diagrams for tap details

# Selection Tables

## HPS Titan N

Encapsulated Transformer

### COPPER WOUND, THREE PHASE

480D Primary Volts

208Y/120 Secondary Volts



60 Hz

kVA	Catalog Number	Case Style	Approx. Dimensions Inches [mm]			Full Capacity Taps	°C Temp. Rise	Approx. Weight Lbs. [kg]	Mtg Type W - Wall F - Floor	Wiring Diagram
			Width	Depth	Height					
2	TN2A0002KBKA	DQT1	13.13 [333.51]	9.13 [231.91]	13.38 [339.86]	2 - 5% 1FCAN, 1FCBN	80	74 [33.3]	W/F	SCD 1.3
3	TN2A0003KBKA	DQT1	13.13 [333.51]	9.13 [231.91]	13.38 [339.86]	2 - 5% 1FCAN, 1FCBN	80	78 [35.1]	W/F	SCD 1.3
6	TN2A0006KBKF	DQT2	15.88 [403.36]	9.88 [250.96]	15.38 [390.66]	2 - 5% 1FCAN, 1FCBN	115	140 [63]	W/F	SCD 1.3
9	TN2A0009KBKF	DQT3	19.13 [485.91]	11.88 [301.76]	14.69 [373.13]	2 - 5% 1FCAN, 1FCBN	115	200 [90]	W/F	SCD 1.3
15	TN2A0015KBKF	DQT4	22.38 [568.46]	13.88 [352.56]	17.25 [438.15]	6 - 2.5% 2FCAN, 4FCBN	115	310 [140]	W/F	SCD 2.3
30	TN2A0030KBKF	DQT5	25.88 [657.36]	16.50 [419.10]	21.88 [555.76]	6 - 2.5% 2FCAN, 4FCBN	115	510 [230]	F (Opt. W)	SCD 2.3
45	TN2A0045KBKF	DQT6	26.13 [663.71]	19.75 [501.65]	21.88 [555.76]	6 - 2.5% 2FCAN, 4FCBN	115	635 [286]	F (Opt. W)	SCD 2.3
75	TN2A0075KBKF	DQT7	32.38 [822.46]	22.00 [558.80]	25.63 [651.01]	6 - 2.5% 2FCAN, 4FCBN	115	1180 [531]	F	SCD 2.3
112.5	TN2A0112KBKF	DQT9	36.63 [930.41]	30.75 [781.05]	25.63 [651.01]	6 - 2.5% 2FCAN, 4FCBN	115	2000 [900]	F	SCD 2.3
150	TN2A0150KBKF	DQT10	36.63 [930.41]	30.50 [774.70]	31.38 [797.06]	6 - 2.5% 2FCAN, 4FCBN	115	2700 [1215]	F	SCD 2.3

Refer to wiring diagrams for tap details

Opt. W: Wall Mounting Kit "DQTW1" Available

480D Primary Volts

240D Secondary Volts

60 Hz

kVA	Catalog Number	Case Style	Approx. Dimensions Inches [mm]			Full Capacity Taps	°C Temp. Rise	Approx. Weight Lbs. [kg]	Mtg Type W - Wall F - Floor	Wiring Diagram
			Width	Depth	Height					
2	TN2D0002KDKA	DQT1	13.13 [333.51]	9.13 [231.91]	13.38 [339.86]	2 - 5% 1FCAN, 1FCBN	80	74 [33.3]	W/F	SCD 3.3
3	TN2D0003KDKA	DQT1	13.13 [333.51]	9.13 [231.91]	13.38 [339.86]	2 - 5% 1FCAN, 1FCBN	80	78 [35.1]	W/F	SCD 3.3
6	TN2D0006KDKF	DQT2	15.88 [403.36]	9.88 [250.96]	15.38 [390.66]	2 - 5% 1FCAN, 1FCBN	115	140 [63]	W/F	SCD 3.3
9	TN2D0009KDKF	DQT3	19.13 [485.91]	11.88 [301.76]	14.69 [373.13]	2 - 5% 1FCAN, 1FCBN	115	200 [90]	W/F	SCD 3.3
15	TN2D0015KDKF	DQT4	22.38 [568.46]	13.88 [352.56]	17.25 [438.15]	6 - 2.5% 2FCAN, 4FCBN	115	310 [140]	W/F	SCD 4.3
30	TN2D0030KDKF	DQT5	25.88 [657.36]	16.50 [419.10]	21.88 [555.76]	6 - 2.5% 2FCAN, 4FCBN	115	510 [230]	F (Opt. W)	SCD 4.3
45	TN2D0045KDKF	DQT6	26.13 [663.71]	19.75 [501.65]	21.88 [555.76]	6 - 2.5% 2FCAN, 4FCBN	115	635 [286]	F (Opt. W)	SCD 4.3
75	TN2D0075KDKF	DQT7	32.38 [822.46]	22.00 [558.80]	25.63 [651.01]	6 - 2.5% 2FCAN, 4FCBN	115	1180 [531]	F	SCD 4.3
112.5	TN2D0112KDKF	DQT9	36.63 [930.41]	30.75 [781.05]	25.63 [651.01]	6 - 2.5% 2FCAN, 4FCBN	115	2000 [900]	F	SCD 4.3
150	TN2D0150KDKF	DQT10	36.63 [930.41]	30.50 [774.70]	31.38 [797.06]	6 - 2.5% 2FCAN, 4FCBN	115	2700 [1215]	F	SCD 4.3

Refer to wiring diagrams for tap details

Opt. W: Wall Mounting Kit "DQTW1" Available

480D Primary Volts

400Y/231 Secondary Volts

60 Hz

kVA	Catalog Number	Case Style	Approx. Dimensions Inches [mm]			Full Capacity Taps	°C Temp. Rise	Approx. Weight Lbs. [kg]	Mtg Type W - Wall F - Floor	Wiring Diagram
			Width	Depth	Height					
2	TN2A0002KHKA	DQT1	13.13 [333.51]	9.13 [231.91]	13.38 [339.86]	2 - 5% 1FCAN, 1FCBN	80	74 [33.3]	W/F	SCD 1.3
3	TN2A0003KHKA	DQT1	13.13 [333.51]	9.13 [231.91]	13.38 [339.86]	2 - 5% 1FCAN, 1FCBN	80	78 [35.1]	W/F	SCD 1.3
6	TN2A0006KHKF	DQT2	15.88 [403.36]	9.88 [250.96]	15.38 [390.66]	2 - 5% 1FCAN, 1FCBN	115	140 [63]	W/F	SCD 1.3
9	TN2A0009KHKF	DQT3	19.13 [485.91]	11.88 [301.76]	14.69 [373.13]	2 - 5% 1FCAN, 1FCBN	115	200 [90]	W/F	SCD 1.3
15	TN2A0015KHKF	DQT4	22.38 [568.46]	13.88 [352.56]	17.25 [438.15]	6 - 2.5% 2FCAN, 4FCBN	115	310 [140]	W/F	SCD 2.3
30	TN2A0030KHKF	DQT5	25.88 [657.36]	16.50 [419.10]	21.88 [555.76]	6 - 2.5% 2FCAN, 4FCBN	115	510 [230]	F (Opt. W)	SCD 2.3
45	TN2A0045KHKF	DQT6	26.13 [663.71]	19.75 [501.65]	21.88 [555.76]	6 - 2.5% 2FCAN, 4FCBN	115	635 [286]	F (Opt. W)	SCD 2.3
75	TN2A0075KHKF	DQT7	32.38 [822.46]	22.00 [558.80]	25.63 [651.01]	6 - 2.5% 2FCAN, 4FCBN	115	1180 [531]	F	SCD 2.3
112.5	TN2A0112KHKF	DQT9	36.63 [930.41]	30.75 [781.05]	25.63 [651.01]	6 - 2.5% 2FCAN, 4FCBN	115	2000 [900]	F	SCD 2.3
150	TN2A0150KHKF	DQT10	36.63 [930.41]	30.50 [774.70]	31.38 [797.06]	6 - 2.5% 2FCAN, 4FCBN	115	2700 [1215]	F	SCD 2.3

Refer to wiring diagrams for tap details

Opt. W: Wall Mounting Kit "DQTW1" Available

# Selection Tables

HPS Titan N  
Encapsulated Transformer



60 Hz

## COPPER WOUND, THREE PHASE

600D Primary Volts      208Y/120 Secondary Volts

kVA	Catalog Number	Case Style	Approx. Dimensions Inches [mm]			Full Capacity Taps	°C Temp. Rise	Approx. Weight Lbs. [kg]	Mtg Type W - Wall F - Floor	Wiring Diagram
			Width	Depth	Height					
2	TN2A0002PBKA	DQT1	13.13 [333.51]	9.13 [231.91]	13.38 [339.86]	2 - 5% 1FCAN, 1FCBN	80	74 [33.3]	W/F	SCD 1.3
3	TN2A0003PBKA	DQT1	13.13 [333.51]	9.13 [231.91]	13.38 [339.86]	2 - 5% 1FCAN, 1FCBN	80	78 [35.1]	W/F	SCD 1.3
6	TN2A0006PBKF	DQT2	15.88 [403.36]	9.88 [250.96]	15.38 [390.66]	2 - 5% 1FCAN, 1FCBN	115	140 [63]	W/F	SCD 1.3
9	TN2A0009PBKF	DQT3	19.13 [485.91]	11.88 [301.76]	14.69 [373.13]	2 - 5% 1FCAN, 1FCBN	115	200 [90]	W/F	SCD 1.3
15	TN2A0015PBKF	DQT4	22.38 [568.46]	13.88 [352.56]	17.25 [438.15]	6 - 2.5% 2FCAN, 4FCBN	115	310 [140]	W/F	SCD 2.3
30	TN2A0030PBKF	DQT5	25.88 [657.36]	16.50 [419.10]	21.88 [555.76]	6 - 2.5% 2FCAN, 4FCBN	115	510 [230]	F (Opt. W)	SCD 2.3
45	TN2A0045PBKF	DQT6	26.13 [663.71]	19.75 [501.65]	21.88 [555.76]	6 - 2.5% 2FCAN, 4FCBN	115	635 [286]	F (Opt. W)	SCD 2.3
75	TN2A0075PBKF	DQT7	32.38 [822.46]	22.00 [558.80]	25.63 [651.01]	6 - 2.5% 2FCAN, 4FCBN	115	1180 [531]	F	SCD 2.3
112.5	TN2A0112PBKF	DQT9	36.63 [930.41]	30.75 [781.05]	25.63 [651.01]	6 - 2.5% 2FCAN, 4FCBN	115	2000 [900]	F	SCD 2.3
150	TN2A0150PBKF	DQT10	36.63 [930.41]	30.50 [774.70]	31.38 [797.06]	6 - 2.5% 2FCAN, 4FCBN	115	2700 [1215]	F	SCD 2.3

Refer to wiring diagrams for tap details

Opt. W: Wall Mounting Kit "DQTW1" Available

600D, 480D Primary Volts      480Y/277 Secondary Volts

60 Hz

kVA	Catalog Number	Case Style	Approx. Dimensions Inches [mm]			Full Capacity Taps	°C Temp. Rise	Approx. Weight Lbs. [kg]	Mtg Type W - Wall F - Floor	Wiring Diagram
			Width	Depth	Height					
2	TN2A0002QKKA	DQT1	13.13 [333.51]	9.13 [231.91]	13.38 [339.86]	3 - 5% 1FCAN, 2FCBN	80	79 [35.6]	W/F	SCD 5.3
3	TN2A0003QKKA	DQT1	13.13 [333.51]	9.13 [231.91]	13.38 [339.86]	3 - 5% 1FCAN, 2FCBN	80	85 [38.3]	W/F	SCD 5.3
6	TN2A0006QKKF	DQT2	15.88 [403.36]	9.88 [250.96]	15.38 [390.66]	3 - 5% 1FCAN, 2FCBN	115	150 [68]	W/F	SCD 5.3
9	TN2A0009QKKF	DQT3	19.13 [485.91]	11.88 [301.76]	14.69 [373.13]	3 - 5% 1FCAN, 2FCBN	115	210 [95]	W/F	SCD 5.3
15	TN2A0015QKKF	DQT4	22.38 [568.46]	13.88 [352.56]	17.25 [438.15]	3 - 5% 1FCAN, 2FCBN	115	320 [144]	W/F	SCD 6.3
30	TN2A0030QKKF	DQT5	25.88 [657.36]	16.50 [419.10]	21.88 [555.76]	3 - 5% 1FCAN, 2FCBN	115	520 [234]	F (Opt. W)	SCD 6.3
45	TN2A0045QKKF	DQT6	26.13 [663.71]	19.75 [501.65]	21.88 [555.76]	3 - 5% 1FCAN, 2FCBN	115	665 [300]	F (Opt. W)	SCD 6.3
75	TN2A0075QKKF	DQT7	32.38 [822.46]	22.00 [558.80]	25.63 [651.01]	3 - 5% 1FCAN, 2FCBN	115	1270 [572]	F	SCD 6.3
112.5	TN2A0112QKKF	DQT9	36.63 [930.41]	30.75 [781.05]	25.63 [651.01]	3 - 4.5% 1FCAN, 2FCBN	115	2200 [990]	F	SCD 6.3
150	TN2A0150QKKF	DQT10	36.63 [930.41]	30.50 [774.70]	31.38 [797.06]	3 - 4.5% 1FCAN, 2FCBN	115	2900 [1305]	F	SCD 6.3

Refer to wiring diagrams for tap details

Opt. W: Wall Mounting Kit "DQTW1" Available

## DQTW1 Wall Mounting Kit

The DQTW1 HPS wall mounting kits are specifically designed for standard and custom HPS Titan® N encapsulated distribution transformers.

The DQTW1 kit is can only be used on any unit up to a maximum of 800 pounds (363 kg) that utilizes an HPS DQT5 or DQT6 enclosure. Generally this would be a 30kVA or 45kVA HPS Titan® N unit.

### IMPORTANT

Please ensure your wall mounting location and position meets all local building and fire codes and regulations

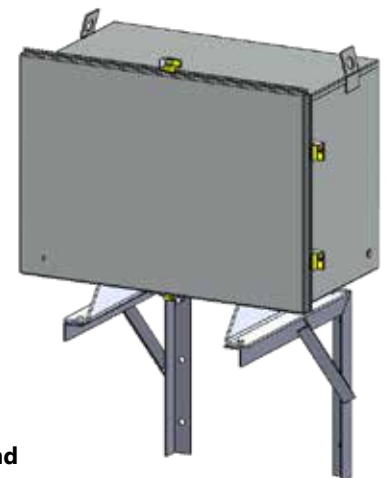

# Selection Tables

## HPS Titan X

Encapsulated Transformer



**IECEX, ATEX & UKEx**

### COPPER WOUND, THREE PHASE

480D Primary Volts

400Y/231 Secondary Volts

60 Hz

kVA	Catalog Number	Case Style	Approx. Dimensions Inches [mm]			Full Capacity Taps	°C Temp. Rise	Approx. Weight Lbs. [kg]	Mtg Type W - Wall F - Floor	Wiring Diagram
			Width	Depth	Height					
6	<b>TX2A0006KHKF</b>	DQT2	15.88 [403.36]	9.88 [250.96]	15.38 [390.66]	2 - 5% 1FCAN, 1FCBN	115	140 [63.0]	W/F	SCD 1
9	<b>TX2A0009KHKF</b>	DQT3	13.19 [335.03]	11.88 [301.76]	14.69 [373.13]	2 - 5% 1FCAN, 1FCBN	115	200 [90.0]	W/F	SCD 1
15	<b>TX2A0015KHKF</b>	DQT4	22.38 [568.46]	13.88 [352.56]	17.25 [438.15]	6 - 2.5% 2FCAN, 4FCBN	115	310 [139.5]	W/F	SCD 2
30	<b>TX2A0030KHKF</b>	DQT5	25.88 [657.36]	16.50 [419.10]	21.88 [555.76]	6 - 2.5% 2FCAN, 4FCBN	115	510 [229.5]	F (Opt. W)	SCD 2
45	<b>TX2A0045KHKF</b>	DQT6	26.13 [663.71]	19.75 [501.65]	21.88 [555.76]	6 - 2.5% 2FCAN, 4FCBN	115	635 [285.8]	F (Opt. W)	SCD 2
75	<b>TX2A0075KHKF</b>	DQT7	32.38 [822.46]	22.00 [558.80]	25.63 [651.01]	6 - 2.5% 2FCAN, 4FCBN	115	1180 [531.0]	F	SCD 2

Opt. W: Wall Mounting Kit "DQTW1" Available

480D Primary Volts

208Y/120 Secondary Volts

60 Hz

kVA	Catalog Number	Case Style	Approx. Dimensions Inches [mm]			Full Capacity Taps	°C Temp. Rise	Approx. Weight Lbs. [kg]	Mtg Type W - Wall F - Floor	Wiring Diagram
			Width	Depth	Height					
6	<b>TX2A0006KBKF</b>	DQT2	15.88 [403.36]	9.88 [250.96]	15.38 [390.66]	2 - 5% 1FCAN, 1FCBN	115	140 [63.0]	W/F	SCD 1
9	<b>TX2A0009KBKF</b>	DQT3	13.19 [335.03]	11.88 [301.76]	14.69 [373.13]	2 - 5% 1FCAN, 1FCBN	115	200 [90.0]	W/F	SCD 1
15	<b>TX2A0015KBKF</b>	DQT4	22.38 [568.46]	13.88 [352.56]	17.25 [438.15]	6 - 2.5% 2FCAN, 4FCBN	115	310 [139.5]	W/F	SCD 2
30	<b>TX2A0030KBKF</b>	DQT5	25.88 [657.36]	16.50 [419.10]	21.88 [555.76]	6 - 2.5% 2FCAN, 4FCBN	115	510 [229.5]	F (Opt. W)	SCD 2
45	<b>TX2A0045KBKF</b>	DQT6	26.13 [663.71]	19.75 [501.65]	21.88 [555.76]	6 - 2.5% 2FCAN, 4FCBN	115	635 [285.8]	F (Opt. W)	SCD 2
75	<b>TX2A0075KBKF</b>	DQT7	32.38 [822.46]	22.00 [558.80]	25.63 [651.01]	6 - 2.5% 2FCAN, 4FCBN	115	1180 [531.0]	F	SCD 2

Opt. W: Wall Mounting Kit "DQTW1" Available

400D Primary Volts

230Y/133 Secondary Volts

50/60 Hz

kVA	Catalog Number	Case Style	Approx. Dimensions Inches [mm]			Full Capacity Taps	°C Temp. Rise	Approx. Weight Lbs. [kg]	Mtg Type W - Wall F - Floor	Wiring Diagram
			Width	Depth	Height					
6	<b>TX2A0006HCKF5</b>	DQT3	13.19	11.88	14.69	2 - 5% 1FCAN, 1FCBN	115	205	W/F	SCD1
9	<b>TX2A0009HCKF5</b>	DQT4	22.38	13.88	17.25	2 - 5% 1FCAN, 1FCBN	115	260	W/F	SCD1
15	<b>TX2A0015HCKF5</b>	DQT5	25.88	16.50	21.88	6 - 2.5% 2FCAN, 4FCBN	115	405	F (Opt. W)	SCD 2
30	<b>TX2A0030HCKF5</b>	DQT6	26.13	19.75	21.88	6 - 2.5% 2FCAN, 4FCBN	115	530	F (Opt. W)	SCD 2
45	<b>TX2A0045HCKF5</b>	DQT7	32.38	22.00	25.63	6 - 2.5% 2FCAN, 4FCBN	115	900	F	SCD 2
75	<b>TX2A0075HCKF5</b>	DQT8	35.13	26.00	26.63	6 - 2.5% 2FCAN, 4FCBN	115	1350	F	SCD 2

Opt. W: Wall Mounting Kit "DQTW1" Available

600D Primary Volts

208Y/120 Secondary Volts

60 Hz

kVA	Catalog Number	Case Style	Approx. Dimensions Inches [mm]			Full Capacity Taps	°C Temp. Rise	Approx. Weight Lbs. [kg]	Mtg Type W - Wall F - Floor	Wiring Diagram
			Width	Depth	Height					
6	<b>TX2A0006PBKF</b>	DQT2	15.88 [403.36]	9.88 [250.96]	15.38 [390.66]	2 - 5% 1FCAN, 1FCBN	115	140 [63.0]	W/F	SCD1
9	<b>TX2A0009PBKF</b>	DQT3	13.19 [335.03]	11.88 [301.76]	14.69 [373.13]	2 - 5% 1FCAN, 1FCBN	115	200 [90.0]	W/F	SCD1
15	<b>TX2A0015PBKF</b>	DQT4	22.38 [568.46]	13.88 [352.56]	17.25 [438.15]	6 - 2.5% 2FCAN, 4FCBN	115	310 [139.5]	W/F	SCD 2
30	<b>TX2A0030PBKF</b>	DQT5	25.88 [657.36]	16.50 [419.10]	21.88 [555.76]	6 - 2.5% 2FCAN, 4FCBN	115	510 [229.5]	F (Opt. W)	SCD 2
45	<b>TX2A0045PBKF</b>	DQT6	26.13 [663.71]	19.75 [501.65]	21.88 [555.76]	6 - 2.5% 2FCAN, 4FCBN	115	635 [285.8]	F (Opt. W)	SCD 2
75	<b>TX2A0075PBKF</b>	DQT7	32.38 [822.46]	22.00 [558.80]	25.63 [651.01]	6 - 2.5% 2FCAN, 4FCBN	115	1180 [531.0]	F	SCD 2

Opt. W: Wall Mounting Kit "DQTW1" Available

## Single Phase

**Voltage Range 120V to 600V  
80°C to 115°C Temp. Rise**

kVA	Impedance	Peak Inrush Current Multiple of RMS Current	
0.5	4-7%	Consult HPS	
0.75			
1			
1.5			
2	1-2%		
3			
5			
7.5			
10	2-4%		30 to 40
15			
25			
37.5			

## Three Phase

**Voltage Range 120V to 600V  
80°C to 115°C Temp. Rise**

kVA	Impedance	Peak Inrush Current Multiple of RMS Current	
2	3.5-6.5%	15 to 20	
3			
6			
9	2-5%		
15			
30			
45	1.8-4%		10 to 18
75			
112.5	1.8-2.5%		6-12
150			

**Efficiency (% rated load)**

kVA	100%	50%	35%
2	95.02%	95.97%	94.37%
3	95.96%	97.44%	96.71%
6	95.24%	95.75%	94.67%
9	97.38%	98.23%	97.93%
15	97.79%	98.41%	98.15%*
30	98.28%	98.85%	98.75%*
45	98.60%	98.97%	98.84%*
75	98.93%	99.03%	98.82%*
112.5	99.08%	99.03%	98.82%
150	99.15%	99.13%	98.96%

- Efficiencies are approximate, and not guaranteed
- All efficiencies are based on 75°C reference temperature
- Applies only to 115°C rise, with the exception of 2 & 3 kVA
- \*Items from 15-75kVA meet the current minimum efficiency levels in North America (DOE 2016 & NRCan 2019) for ventilated transformers. Note that these efficiency levels are not required for this non-ventilated offering.

# Termination Details

## Copper Termination, Leads or Pads

### Single Phase Voltages (Primary or Secondary)

kVA	208	240	277	347	380	400	480	600
0.5	Lead Wire							
0.75								
1								
1.5								
2								
3								
5								
7.5								
10	1A	1A	1A					
15	1A	1A	1A	1A	1A	1A	1A	1A
25	1B	1B	1B	1A	1A	1A	1A	1A
37.5	1D	1C	1C	1C	1C	1C	1C	1B

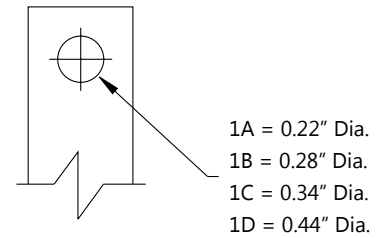

DIAGRAM 1 - Single Phase

### HPS Titan N Three Phase Voltages (Primary or Secondary)

kVA	208	230	240	277	380	400	480	600
2	Lead Wire							
3								
6								
9*	1A	1A	1A	1A	1A			
15	1A	1A	1A	1A	1A	1A	1A	1A
30	1A	1A	1A	1A	1A	1A	1A	1A
45	1B	1A	1A	1A	1A	1A	1A	1A
75	1B	1B	1B	1B	1A	1A	1A	1A
112.5	1B	1B	1B	1B	1B	1B	1B	1A
150	1B	1B	1B	1B	1B	1B	1B	1B

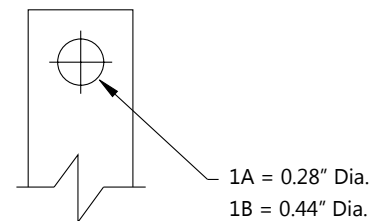

DIAGRAM 1 - Three Phase

\* Termination Tab 1A provided on 9 kVA 80°C, and 95°C rise only. Otherwise, 115°C rise have lead wire terminations.

### HPS Titan X Three Phase Voltages (Primary or Secondary)

kVA	208	230	240	277	380	400	480	600
6*	1A	1A	1A	1A	1A	1A	1A	1A
9	1A	1A	1A	1A	1A	1A	1A	1A
15	1A	1A	1A	1A	1A	1A	1A	1A
30	1A	1A	1A	1A	1A	1A	1A	1A
45	1B	1A	1A	1A	1A	1A	1A	1A
75	1B	1B	1B	1B	1A	1A	1A	1A

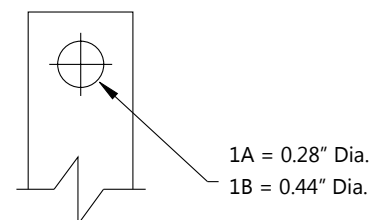
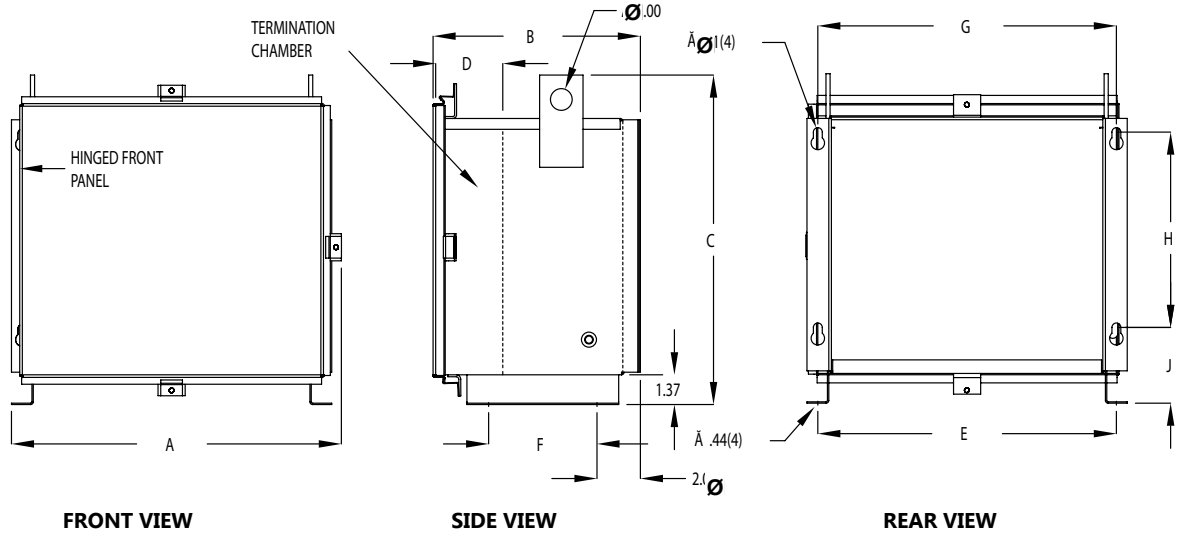

DIAGRAM 1 - Three Phase

\* Termination Tab 1A provided on 6 kVA 50Hz or 50/60Hz, 115°C & 80°C rise. For 60Hz 115°C rise, terminal block provided

**Figure 1**



**Figure 2**

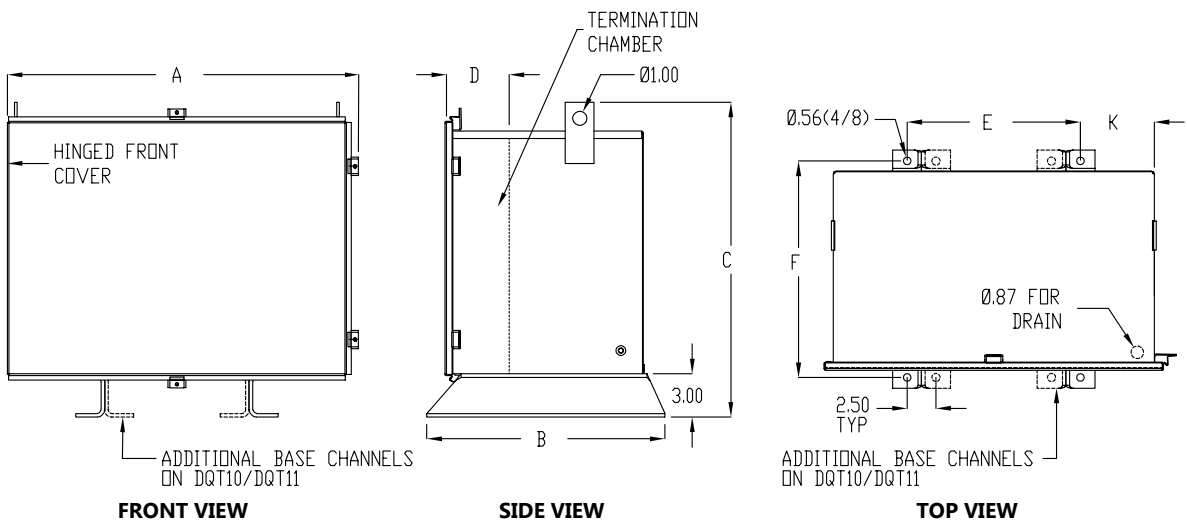

Case Style	Fig. #	Dimensions in Inches [mm]									
		A	B	C	D*	E	F	G	H	J	K
DQT1	1	13.13 [333.51]	9.13 [231.91]	13.38 [339.86]	2.50 [63.50]	11.50 [292.10]	5.25 [133.35]	11.50 [292.10]	6.50 [165.10]	3.69 [93.73]	-
DQT2	1	15.88 [403.36]	9.88 [250.96]	15.38 [390.66]	2.50 [63.50]	14.25 [361.95]	6.00 [152.40]	14.25 [361.95]	8.00 [203.20]	3.69 [93.73]	-
DQT3	1	19.13 [485.91]	11.88 [301.76]	14.69 [373.13]	3.00 [76.20]	17.50 [444.50]	8.00 [203.20]	17.50 [444.50]	8.00 [203.20]	3.44 [87.38]	-
DQT4	1	22.38 [568.46]	13.88 [352.56]	17.25 [438.15]	5.00 [127.00]	20.75 [527.05]	10.00 [254.00]	20.75 [527.05]	9.00 [228.60]	3.69 [93.73]	-
DQT5	2	25.88 [657.36]	16.50 [419.10]	21.88 [555.76]	4.50 [114.30]	14.00 [355.60]	15.00 [381.00]	-	-	-	4.62 [117.35]
DQT6	2	26.13 [663.71]	19.75 [501.65]	21.88 [555.76]	5.50 [139.70]	14.00 [355.60]	18.25 [463.55]	-	-	-	4.75 [120.65]
DQT7	2	32.38 [822.46]	22.00 [558.80]	25.63 [651.01]	6.00 [152.40]	20.00 [508.00]	20.50 [520.70]	-	-	-	4.88 [123.96]
DQT8	2	35.13 [892.31]	26.00 [660.40]	26.63 [676.41]	6.00 [152.40]	20.00 [508.00]	24.50 [622.30]	-	-	-	6.25 [158.75]
DQT9	2	36.63 [930.41]	30.75 [781.05]	25.63 [651.01]	6.50 [165.10]	20.00 [508.00]	29.25 [742.95]	-	-	-	7.00 [177.80]
DQT10	2	36.63 [930.41]	30.50 [774.70]	31.38 [797.06]	7.00 [177.80]	20.50 [520.70]	29.00 [736.60]	-	-	-	6.75 [171.45]
DQT11	2	38.88 [987.56]	32.25 [819.15]	33.13 [841.51]	7.00 [177.80]	20.50 [520.70]	30.75 [781.05]	-	-	-	7.88 [200.16]

\*D represents the typical minimum depth of the termination chamber (conduit fittings should be sized within these limits)

# Enclosure Drawings

## NQ Series - Single Phase

Figure 1

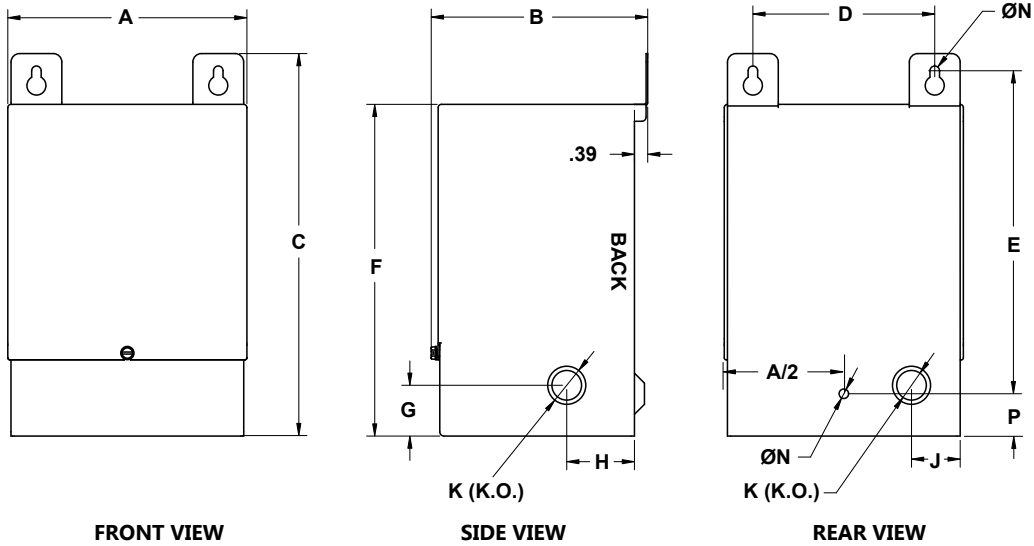
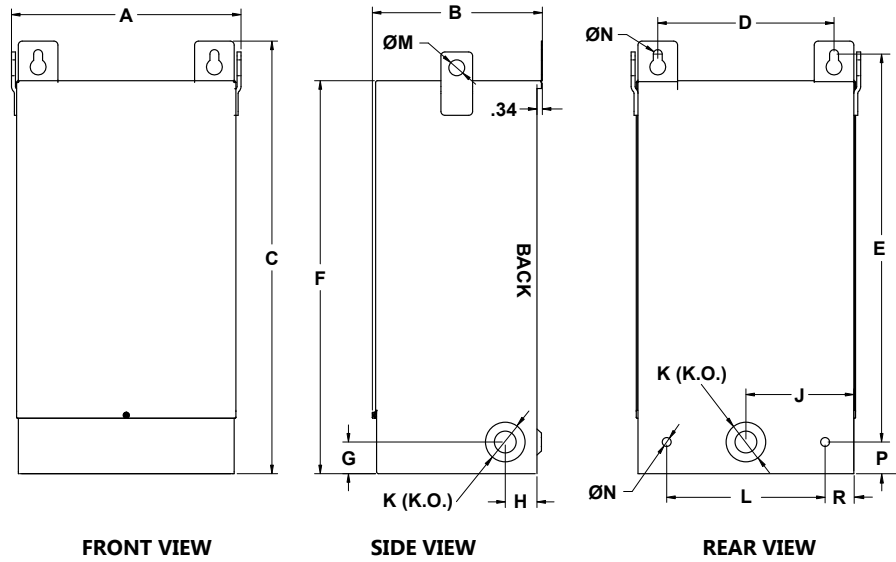

Figure 2



Case Style	Fig. #	Dimensions in Inches [mm]															
		A	B	C	D	E	F	G	H	J	K <sup>1</sup>	L	M	N	P	R	
NQ0	1	3.69 [93.73]	5.06 [128.53]	7.19 [182.63]	2.50 [63.50]	5.63 [143.01]	6.19 [157.23]	1.50 [38.10]	2.00 [50.80]	--	0.88 [22.36]	--	--	0.22 [5.59]	1.25 [31.75]	--	
NQ1	1	4.31 [109.48]	5.56 [141.23]	7.19 [182.63]	3.13 [79.51]	5.63 [143.01]	6.13 [155.71]	1.50 [38.10]	2.00 [50.80]	0.81 [20.58]	0.88 [22.36]	--	--	0.22 [5.59]	1.25 [31.75]	--	
NQ2	1	5.06 [128.53]	4.56 [115.83]	9.30 [236.22]	3.88 [98.56]	7.75 [196.85]	8.30 [210.82]	1.50 [38.10]	2.00 [50.80]	1.00 [25.40]	0.88 X 1.13 X 1.38 [22.36 X 28.71 X 35.06]	--	--	0.22 [5.59]	1.25 [31.75]	--	
NQ3	1	5.88 [149.36]	5.19 [131.83]	10.56 [268.23]	4.13 [104.91]	8.31 [211.08]	9.06 [230.13]	1.50 [38.10]	2.00 [50.80]	1.25 [31.75]	0.88 X 1.13 X 1.38 [22.36 X 28.71 X 35.07]	--	--	0.28 [7.12]	1.25 [31.75]	--	
NQ4	1	7.06 [179.33]	6.25 [158.75]	11.75 [298.45]	5.38 [136.66]	10.00 [254.00]	10.30 [261.62]	1.25 [31.75]	2.00 [50.80]	1.50 [38.10]	0.88 X 1.13 X 1.38 [22.36 X 28.71 X 35.08]	--	--	0.28 [7.12]	1.25 [31.75]	--	
NQ5	2	10.00 [254.00]	7.75 [196.85]	17.25 [438.15]	7.38 [187.46]	15.38 [390.66]	15.25 [387.35]	2.38 [60.33]	2.00 [50.80]	4.00 [101.60]	1.13 X 1.38 [28.71 X 35.06]	6.00 [152.40]	0.75 [19.05]	0.44 [11.18]	1.25 [31.75]	1.68 [42.68]	
NQ6	2	12.25 [311.15]	9.25 [234.95]	20.88 [530.36]	9.38 [238.26]	18.13 [460.51]	18.88 [479.56]	2.00 [50.80]	2.00 [50.80]	5.00 [127.00]	1.38 X 2.50 [35.06 X 63.5]	8.00 [203.20]	0.75 [19.05]	0.44 [11.18]	2.00 [50.80]	1.68 [42.68]	
NQ7	2	14.50 [368.30]	10.75 [273.05]	21.38 [543.06]	11.63 [295.41]	18.63 [473.21]	19.38 [492.26]	2.00 [50.80]	2.00 [50.80]	6.00 [152.40]	1.38 X 2.50 [35.06 X 63.5]	10.00 [254.00]	0.75 [19.05]	0.44 [11.18]	2.00 [50.80]	1.81 [45.98]	
NQ8	2	14.50 [368.30]	10.75 [273.05]	27.38 [695.46]	11.13 [282.71]	24.50 [622.30]	24.88 [631.96]	2.00 [50.80]	2.00 [50.80]	6.00 [152.40]	1.38 X 2.50 [35.06 X 63.5]	10.00 [254.00]	0.75 [19.05]	0.56 [14.23]	2.00 [50.80]	1.81 [45.98]	



# Electrical Schematics & Connection Drawings

## SCD 1.1

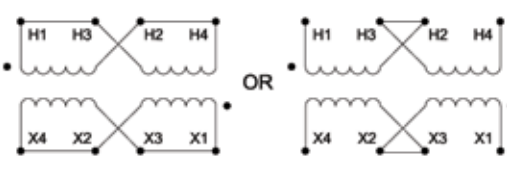
SCHEMATIC			
	Primary Volts	Connect lines to	Inter-connect
	480	H1, H4	H2-H4
	240	H1, H4	H1-H3, H2-H4
	Secondary Volts	Connect lines to	Inter-connect
	240	X1, X4	X2-X3
	120/240	X1, X2, X4	X2-X3
120	X1, X4	X1-X3, X2-X4	

## SCD 1.3

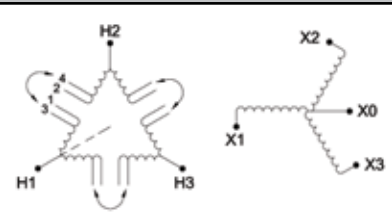
SCHEMATIC		CONNECTIONS			
	% Voltage	Primary Volts	Connect lines to	Inter-connect	
	105.0%	504 630	H1, H2, H3	1-2	
	<b>100.0%</b>	<b>480 600</b>	<b>H1, H2, H3</b>	<b>2-3</b>	
	95.0%	456 570	H1, H2, H3	3-4	
	Secondary Volts	Connect lines to	Inter-connect		
	<b>208 400</b>	X1, X2, X3	-		
	120 231	X1, X0   X2, X0   X3, X0	-		

## SCD 2.1

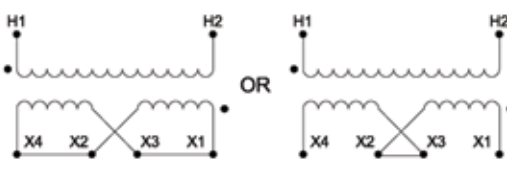
SCHEMATIC			
	Primary Volts	Connect lines to	Inter-connect
	600	H1, H2	-
	Secondary Volts	Connect lines to	Inter-connect
	240	X1, X4	X2-X3
	120/240	X1, X2, X4	X2-X3
	120	X1, X4	X1-X3, X2-X4

## SCD 2.3

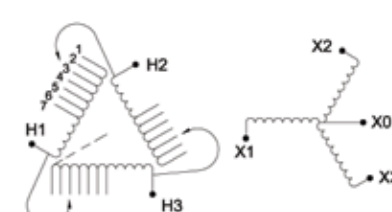
SCHEMATIC		CONNECTIONS			
	% Voltage	Primary Volts	Connect lines to	Inter-connect	
	105.0%	504 630	H1, H2, H3	1	
	102.5%	492 615	H1, H2, H3	2	
	<b>100.0%</b>	<b>480 600</b>	<b>H1, H2, H3</b>	<b>3</b>	
	97.5%	468 585	H1, H2, H3	4	
	95.0%	456 570	H1, H2, H3	5	
	92.5%	444 556	H1, H2, H3	6	
	90.0%	432 542	H1, H2, H3	7	
	Secondary Volts	Connect lines to	Inter-connect		
	<b>208 400</b>	X1, X2, X3	-		
120 231	X1, X0   X2, X0   X3, X0	-			

Tap arrangements shown are for standard products only. May not be applicable for other products.

# Electrical Schematics & Connection Drawings

## SCD 3.1

SCHEMATIC			
	Primary Volts	Connect lines to	Inter-connect
	208	H1, H2	-
	240	H1, H3	-
	277	H1, H4	-
	Secondary Volts	Connect lines to	Inter-connect
	240	X1, X4	X2-X3
120/240	X1, X2, X4	X2-X3	
120	X1, X4	X1-X3, X2-X4	

## SCD 3.3

SCHEMATIC		CONNECTIONS		
	% Voltage	Primary Volts	Connect lines to	Inter-connect
	105.0%	504	H1, H2, H3	1-2
	<b>100.0%</b>	<b>480</b>	<b>H1, H2, H3</b>	<b>2-3</b>
	95.0%	456	H1, H2, H3	3-4
	Secondary Volts	Connect lines to	Inter-connect	
	<b>240</b>	X1, X2, X3	-	

## SCD 4.1

SCHEMATIC			
	Primary Volts	Connect lines to	Inter-connect
	440	H1, H10	H5-H6
	416	H1, H9	H4-H6
	400	H1, H8	H3-H6
	380	H1, H7	H2-H6
	220	H1, H10	H1-H6, H5-H10
	208	H1, H9	H1-H6, H4-H9
	200	H1, H8	H1-H6, H3-H8
	190	H1, H7	H1-H6, H2-H7
	Secondary Volts	Connect lines to	Inter-connect
240	X1, X4	X2-X3	
120/240	X1, X2, X4	X2-X3	
120	X1, X4	X2-X4, X1-X3	

## SCD 4.3

SCHEMATIC		CONNECTIONS		
	% Voltage	Primary Volts	Connect lines to	Inter-connect
	105.0%	504	H1, H2, H3	1
	102.5%	492	H1, H2, H3	2
	<b>100.0%</b>	<b>480</b>	<b>H1, H2, H3</b>	<b>3</b>
	97.5%	468	H1, H2, H3	4
	95.0%	456	H1, H2, H3	5
	92.5%	444	H1, H2, H3	6
	90.0%	432	H1, H2, H3	7
	Secondary Volts	Connect lines to	Inter-connect	
<b>240</b>	X1, X2, X3	-		

Tap arrangements shown are for standard products only. May not be applicable for other products.

### SCD 5.1

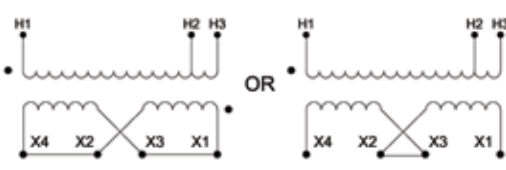
SCHEMATIC		CONNECTIONS		
	Primary Volts	Connect lines to	Inter-connect	
	347	H1, H2	-	
	380	H1, H3	-	
	Secondary Volts	Connect lines to	Inter-connect	
	240	X1, X4	X2-X3	
	120/240	X1, X2, X4	X2-X3	
120	X1, X4	X1-X3, X2-X4		

### SCD 5.3

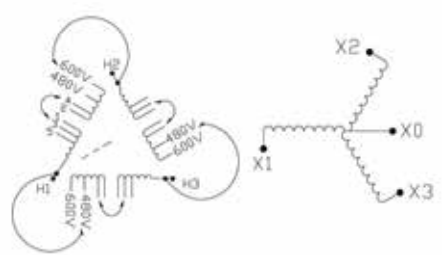
SCHEMATIC		CONNECTIONS			
	% Voltage	Primary Volts	Connect lines to	Inter-connect	
	104%	624	600V	1-2 & H1, H2, H3 to 600V	
	<b>100%</b>	<b>600</b>	<b>600V</b>	<b>2-3 &amp; H1, H2, H3 to 600V</b>	
	96%	576	600V	3-4 & H1, H2, H3 to 600V	
	92%	552	600V	4-5 & H1, H2, H3 to 600V	
	105%	504	480V	1-2 & H1, H2, H3 to 480V	
	<b>100%</b>	<b>480</b>	<b>480V</b>	<b>2-3 &amp; H1, H2, H3 to 480V</b>	
	95%	456	480V	3-4 & H1, H2, H3 to 480V	
	90%	432	480V	4-5 & H1, H2, H3 to 480V	
	Secondary Volts		Connect lines to	Inter-connect	
	480		X1, X2, X3	-	

### SCD 6.3

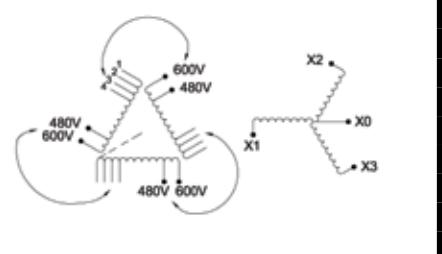
SCHEMATIC		CONNECTIONS				
	<=75 kVA 115°C, 95°C & 80°C		>=112.5 kVA 115°C, 95°C & 80°C		Connect lines to	Inter-connect
	% Voltage	Primary Volts	% Voltage	Primary Volts		
	104%	624	103.2%	624	600V	1-600V
	<b>100%</b>	<b>600</b>	<b>100%</b>	<b>600</b>	<b>600V</b>	<b>2-600V</b>
	96%	576	96.8%	576	600V	3-600V
	92%	552	93.6%	552	600V	4-600V
	105%	504	104.5%	504	480V	1-480V
	<b>100%</b>	<b>480</b>	<b>100%</b>	<b>480</b>	<b>480V</b>	<b>2-480V</b>
	95%	456	95.5%	456	480V	3-480V
	90%	432	91.0%	432	480V	4-480V
	Secondary Volts		Connect lines to		Inter-connect	
480		X1, X2, X3		-		

Tap arrangements shown are for standard products only. May not be applicable for other products.



**CANADA**



**UNITED STATES**



**MEXICO**



**ASIA**

**CANADA**

Hammond Power Solutions  
595 Southgate Drive  
Guelph, Ontario N1G 3W6  
Tel: (519) 822-2441  
Fax: (519) 822-9701  
Toll Free: 1-888-798-8882  
sales@hammondpowersolutions.com

**MEXICO**

Hammond Power Solutions  
Av. No. 800, Parque Industrial Guadalupe  
Guadalupe, NL, Mexico, C.P. 67190.  
Tel: (819) 690-8000  
sales@hammondpowersolutions.com

**UNITED STATES**

Hammond Power Solutions  
1100 Lake Street  
Baraboo, Wisconsin 53913-2866  
Tel: (608) 356-3921  
Fax: (608) 355-7623  
Toll Free: 1-866-705-4684  
sales@hammondpowersolutions.com

**ASIA**

Hammond Power Solutions Pvt. Ltd.  
D. No. 5-2/222/IP/B, II-Floor, Icon Plaza  
Allwyn X-Roads, Miyapur, Hyderabad 500 049  
Tel: +91-994-995-0009  
marketing-india@hammondpowersolutions.com

**EMEA** (Sales Office)

Hammond Power Solutions SpA  
Tel: +49 (152) 08800468  
sales-emea@hammondpowersolutions.com