

Eaton's Crouse-Hinds Division

CROUSE-HINDS
SERIES

Products & solutions for wastewater treatment

EATON

Powering Business Worldwide



Improving safety, energy efficiency and system uptime for water and wastewater facilities

Product solutions

engineered for water treatment



LED lighting

Maintenance-free and energy-efficient

The broadest portfolio of LED luminaires for any industrial or hazardous application. Complete line of HID and fluorescent luminaires also available.



Plugs & receptacles

Simple and secure powering solutions

Extensive configurations, custom capabilities and numerous interlocked designs provide safe and reliable solutions for fixed and portable power applications in industrial and hazardous environments.



Conduit & cable fittings

Rugged connectors for extreme conditions

Time-tested, innovative conduit fittings, cord connectors and cable glands move power where you need it simply and safely in any electrical installation.



Motor control & power distribution

Flexible and modular solutions

Innovative, intelligent NEC and IEC solutions safely and efficiently control power and protect circuits in explosive, wet and corrosive environments worldwide.



Enclosures

Performance and reliability

Available in a comprehensive range of sizes, each with various configurations for a multitude of applications.



Solar solutions

Reduce system costs

Providing the most complete offering of solar combiners, smart combiners, recombiners, disconnects and pass through boxes for your grid-tied solar applications.



Cable management & safety grating

Field flexibility and labor saving design

Structural steel-saving cable management, strut systems and safety grating for slip-resistant walkways.



Specification support

Reducing partner effort

Specification support tools that simplify, streamline and speed up the industrial design and specification process.

Safe. Reliable. Efficient.

Full portfolio of water treatment solutions

Equipment reliability and efficiency is a top concern for water and wastewater treatment plants. When your facility needs to operate continuously, any downtime is a costly event. In addition, rising energy costs are putting greater pressure on operating budgets.

Eaton's Crouse-Hinds Division helps water and wastewater customers improve system uptime, increase safety and improve energy efficiency with its industry-leading portfolio of lighting, power distribution and control products.

Our experience in the water and wastewater market is proven; for over 100 years, we have helped municipalities maintain operations and use power more efficiently – without ever sacrificing safety.

The following pages present some of the key Crouse-Hinds Series products that deliver the performance, energy efficiency and safety you require. For a complete listing of our product solutions for the water and wastewater market, please visit www.crouse-hinds.com/wwtp

Class I, Div. 1 & 2/ Zone 1 & 2

Explosion protection for areas where flammable gases or vapors may normally be present



Industrial

Areas prone to dust, dirt, grime, vibration, hard use and abuse



Wet locations

Protection from rain, splashing, hose directed water and external formation of ice



Space constraints

Areas with low ceilings, tight spaces and limited footprint potential



Corrosive areas

Protection for areas with corrosive chemicals, atmospheres and water



Vibration

Locations with high vibration/continuous movement from motors and other machinery





Hazardous area LED lighting

Hazard•Gard® XPL linear LED luminaires

Overview

Hazard•Gard XPL explosionproof linear LEDs are specifically designed to replace fluorescent T12, T8 and T5HO lighting in Class I, Division 1 and Class II, Division 1 areas. The rugged and durable design features the industry's most versatile and flexible mounting options. The XPL is the ideal lighting solution for hazardous, high vibration, impact and hose down applications.

Certifications

- Class I, Division 1, Groups C, D
- Class II, Division 1, Groups E, F, G
- Class III
- UL844; UL1598; UL1598A
- CSA C22.2 No. 137
- NEMA 4X, IP66, marine and wet locations, paint spray rated
- DesignLights Consortium® approved for select models*

Benefits

- Industry-leading efficacy: up to 120 LPW
- 5000K CCT, 72 CRI
- -25°C to +55°C ambient operating temperature
- Low profile fixture (<5" height)
- Flush and swivel mount options
- Wide optics for uniform illumination
- Four points of secondary retention and loop feed wiring
- 2,000 psi high pressure hose rated
- 5G 3-axis vibration
- 2kV surge protection
- 5 year fixture warranty

Versatile mounting options

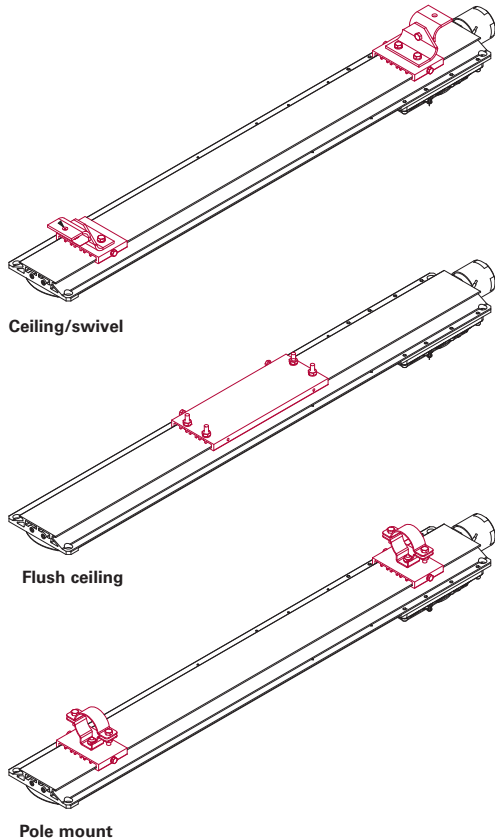

Model number	Equivalent fluorescent luminaire	Typical energy savings/lifetime
XPL2	2 x 2 ft. T5/T8/T12HO	Up to 53% reduction in energy costs and 60,000 hours of continuous operation!
XPL4	2 x 4 ft. T5/T8/T12HO	



XPL2



XPL4



* Refer to www.designlights.org Qualified Products List under Family Models for full listing details. Not all models are approved for all application categories.

Champ® FMV floodlights



Overview

Class I, Division 2 Champ FMV floodlights are hazardous location rated and are designed to provide full-spectrum, crisp, white light.

Nine versions of the FMV LED are available for pole and wall mounting, providing ideal solutions for a wide range of hazardous area applications.

Champ® VMV LED luminaires



Overview

Class I, Division 2 Champ VMV luminaires are designed to provide full-spectrum, crisp, white light with custom Type I, III and V distribution.

Nine versions of the VMV are available, providing ideal solutions for a wide range of applications.

Champ® MLL linear LED luminaires



Overview

Class I, Division 2 Champ MLL linear LED luminaires are specifically designed to replace fluorescent T12, T8 and T5HO lighting. The rugged and durable design features the industry's most versatile and flexible mounting options. The MLL is the ideal solution for high vibration, impact and hose down areas and applications.

Hazard•Gard® EVLL LED luminaires



Overview

The Class I, Division 1 Hazard•Gard EVLL LED product offering provides the same durability and reliability of a traditional HID fixture, coupled with the low cost of ownership and energy efficiency of Eaton's LED technology. High performance LEDs and a solid-state electronic driver provide light where you need it, at a fraction of the operating costs of HID lighting technologies.

Vaporgard™ LED luminaires



Overview

Class I, Division 2 Vaporgard LED luminaires provide uniform crisp, white light and are suitable for lower mounting heights, confined spaces or utility rooms.

Using four high brightness LED arrays, this fixture can deliver similar light levels to 150 watt incandescent lamps.

EV LED luminaires



Overview

The Class I, Division 1 EV LED is built to perform effectively and economically in areas that may be difficult to service, expensive to shut down or any location requiring an increased degree of safety. Compared with conventional lighting, the EV LED consumes up to 85% less energy and typically lasts as long as 50,000 hours or more.

Heavy industrial LED lighting

Champ® Pro PFM LED floodlights



Overview

Champ Pro PFM floodlights are designed to provide full-spectrum, crisp, white light.

Nine versions of the Champ PFM LED are available for pole and wall mounting, providing ideal solutions for a wide range of applications.

Certifications

- UL1598; UL1598A; UL875
- cUL
- Type 4X
- IP66
- DesignLights Consortium® approved for select models*
- UL approved up to 65°C ambient (3L-15L)
- cUL Listed to CSA Standard CSA C22.2 No. 250
- IEC Standards: IEC 60598; CE

Benefits

- Versatile design - Can be used for outdoor or indoor applications, and for a wide range of mounting heights depending on model and light level requirement
- Rugged heat sink - Designed to perform in high ambient temperatures up to +65°C and as low as -40°C
- High lumen output - Up to 117 lumens per watt
- Full-frame yoke - Designed to utilize the SFA6 slipfitter and SWB6 wall mount bracket, making it ideal for retrofit or new installations
- Multiple lens options - Tempered and clear glass standard, polycarbonate and diffused glass options available
- Smaller and lighter - 25% smaller and 10 lbs. (4.5 kg) lighter than previous model (3L-15L models).

Dimensions (3L-15L models)

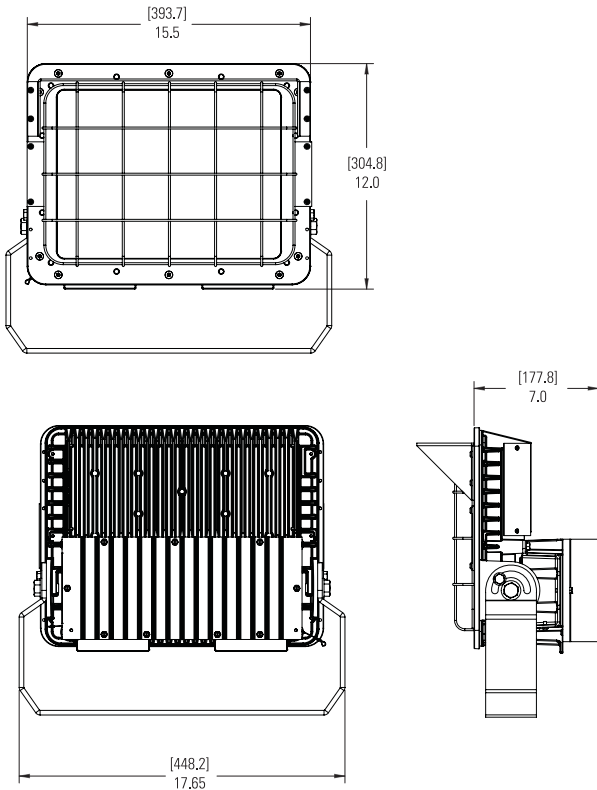

Model number	Equivalent HID luminaire	Typical energy savings/lifetime
PFM3L	70W	Up to 72% reduction in energy costs and 60,000 hours of continuous operation!
PFM5L	100W-150W	
PFM7L	150W-175W	
PFM9L	175W-250W	
PFM11L	250W-400W	
PFM13L	400W	
PFM15L	400W-500W	
PFM25L	600W-750W	
PFM50L	1,500W	



PFM3L – 15L

* Refer to www.designlights.org Qualified Products List under Family Models for full listing details. Not all models are approved for all application categories.

Industrial high bay LED luminaires



Overview

IHB LED luminaires are the perfect replacement for 250W-1,500W HID and 4-10 lamp T5HO fluorescent high bay fixtures. Designed for locations requiring continuous and consistent light levels, requiring frequent on-and-off of lights and that are difficult to relamp or that cause production to be stopped during the lamp maintenance process.

Champ® Pro PVM LED luminaires



Overview

Champ Pro PVM LED luminaires are designed to provide full-spectrum, crisp, white light with custom Type I, III and V distribution.

Nine versions of the PVM are available, providing ideal solutions for a wide range of applications.

Champ® PLL linear LED luminaires



Overview

Champ PLL linear LED luminaires are specifically designed to replace fluorescent T12, T8 and T5HO lighting. The rugged and durable design features the industry's most versatile and flexible mounting options. The PLL is the ideal solution for high vibration, impact and hose down areas and applications.

Vaporgard™ Pro LED luminaires



Overview

Vaporgard LED luminaires provide uniform crisp, white light and are suitable for lower mounting heights, confined spaces or utility rooms.

Using four high brightness LED arrays, this fixture can deliver similar light levels to 150 watt incandescent lamps.

Endure™ LED wall pack



Overview

The IP66, stainless steel Endure LED wall pack features the patented, modular LED LightBAR™ technology. The Endure LED luminaire is available with one or two LightBAR configurations in Type II or Type V distributions.

Ideal for a variety of non-hazardous wastewater treatment applications and general wash down areas.





Plugs & receptacles

PowerMate™ pin and sleeve connectors

Overview

PowerMate plugs and receptacles are used to quickly and efficiently connect power to lighting circuits, motors and pumps in harsh operating environments.

Available in 30, 60, 100, 150 and 200 amp models.

Certifications

- UL Standards: UL1682, UL1686, NEMA 250
- CSA Standard: C22.2 No. 182.1
- Listed for use with Type P cable, flexible cord and cables rated for extra hard usage
- NEMA 4X

Benefits

- Lockout plug guarantees isolated power supply with OSHA compliant lockout/tagout
- Fixed safety insulator prevents electrical shocks and shorts
- 8-point diamond cable clamps provide eight points of contact for increased grip and even pressure distribution
- Split pin contact design provides nearly 360° of contact at every insertion
- Mates with Crouse-Hinds Arkrite®, Appleton® Powertite and Killark® Versamate



Posi-Max power distribution panels



Overview

Posi-Max power distribution panels provide a quick and safe method of connection to portable generators. The unique Posi-Max design allows for quick and safe restoration of essential power services.

The Posi-Max Series is available in 200A to 1200A and the enclosure can be customized to meet specific environmental and configuration needs.

The heart of the system is the field-proven Posi-Lok power distribution system designed to meet Articles 520.53(K) and 530.22(A) of the NEC®. The sequential port interlock requires the user to connect and disconnect each plug in the proper sequence, ensuring ground connection. This single pole system allows for easy connection in any situation.



Posi-Lok™ power distribution panels



Overview

Quick and efficient standby and emergency power

Posi-Lok distribution panels use lightweight, single conductor cables to provide the means for hurried personnel to quickly and safely connect and disconnect power systems without having to use any tools.

Now there's no need to haul around huge, multi-conductor cables. Posi-Lok power distribution systems let you use lighter, single conductor cables rated at higher amperages.

Posi-Lok plugs feature recessed electrical contacts that are protected by shatter-resistant insulators and impact-resistant molded sleeves.

The unique elastomeric tapered insulator allows maximum flexing with minimum breakage. There are no metal clamps or grommets to cause cable failure.



IEC 60309 plugs, connectors, receptacles and inlets



Overview

IEC 60309 pin and sleeve devices are the industry's first to offer IP69K rated protection. Each device has been carefully engineered to offer reliability, efficiency and added safety protection in demanding wet locations, particularly where harsh wash downs are a must.

Arktite® 30A-100A non-metallic plugs, receptacles and connectors



Overview

Arktite circuit breaking plugs, receptacles, cord connectors and motor plugs are used to supply power to portable electrical devices such as welders, motors, pumps, conveyors and other similar equipment where electrical loads must be quickly disconnected from power sources.

Ark•Gard® NEMA configured plugs & receptacles



Overview

Ark•Gard plugs and receptacles make it safe and easy to bring power wherever it is needed. They provide versatility for connecting portable devices in both hazardous and non-hazardous locations. Perfect for applications which require additional environmental protection, or in NEMA 4 hose down environments where wash down/hose downs occur.

Arktite® interlocked receptacles with enclosed disconnect switches



Overview

Arktite supplies power to portable or fixed electrical equipment such as welders, compressors, conveyors, portable tools, lighting systems and similar equipment.

The interlocked receptacle prevents engagement and disengagement of the plug under load, providing safe, portable connections and extended product life.

Fusible or non-fusible versions available in 30, 60 and 100 amp configurations.

Roughneck® multi-pin and single pole connectors



Overview

Multi-pin connectors
Heavy duty control and instrumentation multi-pin connectors for hazardous and harsh industrial use.

Single pole connectors
Secure, single pole power, rated to 1135A for use in hazardous and normal locations.



Industrial/commercial fittings and glands

V-Spring® telescoping safety light pole



Overview

The V-Spring telescoping safety light pole increases safety and decreases labor costs associated with lighting installation and routine maintenance. Its innovative design allows for all work to safely take place on the platform or walkway, eliminating the need for portable ladders and fall protection equipment. Applications include:

- Luminaires installed on industrial walkways, platforms, stairways and conveyors where OSHA/HSE regulations require fall prevention equipment
- Hard to reach or dangerous areas where safety is a big concern
- Hazardous and harsh environments subject to corrosive agents, vibration and extreme temperatures

Benefits

- Spring assist - Provides true controlled lowering; less force required to raise or lower luminaire – no strain on worker; eliminates the need for portable ladders and fall prevention equipment
- Easy fixture orientation - Adjustable 360° pole rotation allows for effortless positioning of light
- Simple vertical travel - Easily extend to any raised height – one product covers multiple mounting heights;
- Simple operation - Innovative design eliminates consideration of surrounding obstructions; easily adjust fixture position from ground or walkway
- Designed for harsh environments - No lubricants or maintenance required; suitable for dusttight applications; optional harsh environment cover eliminates moisture and airborne contaminants
- Fully assembled and wired - Factory assembled wired and sealed for maximum environmental protection

Certifications

- NEC/CEC: cULus Listed for Class I, Division 2 and Class II, Division 2 hazardous areas when used with Champ® luminaires; UL1598; CSA C22.2 No. 250.0-08
- Environmental ratings: dusttight; NEMA 4; IP66
- Vibration: DNV No. 2.4: 2006; IEC 60068-2-6: 2007

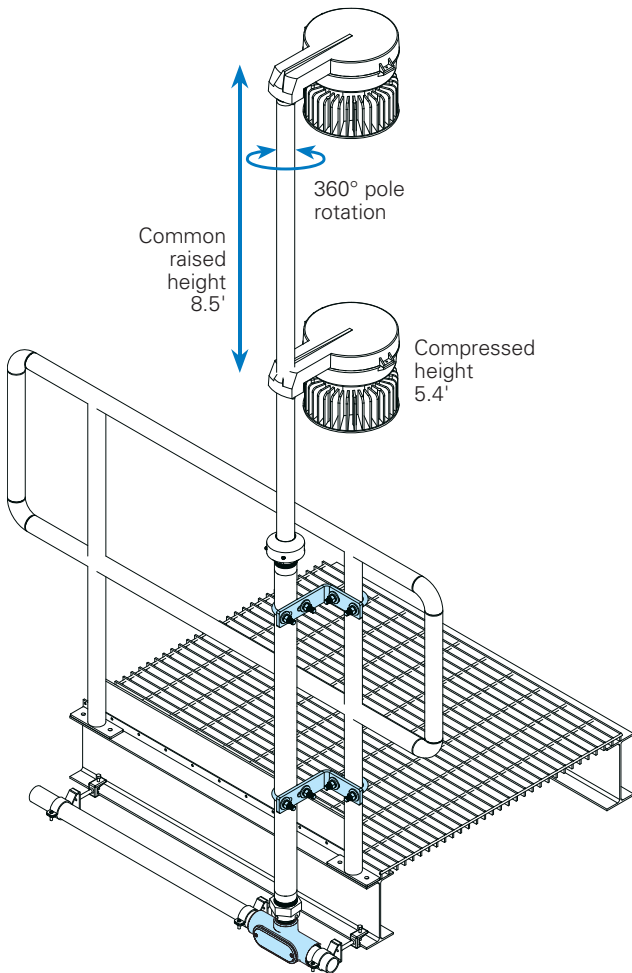

Condulet® conduit bodies, boxes, covers and gaskets



Overview

Condulet boxes are installed in conduit systems to: accommodate wiring devices, act as pull boxes, provide openings to make 90° bends, provide for splices, taps, mounting outlets and provide access to conductors for maintenance and future system changes.

Terminator™ II TMCX armoured barrier & non-armoured barrier glands



Overview

The Terminator II TMCX cable gland is an armoured barrier, non-armoured barrier and TECK armoured gland used to terminate cable in hazardous locations. Its unique design features, coupled with our new fast curing Chico® LiquidSeal compound, make the Terminator II TMCX the easiest and safest solution available.

Explosionproof conduit sealing fittings



Overview

EY and EZ explosionproof conduit sealing fittings are installed in conduit runs to prevent the passage of gases, vapors or flames from one portion of the electrical installation to another through the conduit, limiting any explosion to the enclosure and preventing pre-compression or "pressure piling."

Available with or without drains.

Chico® SpeedSeal™ compound



Overview

Designed to separate and form an explosionproof seal around each electrical conductor in Eaton's Crouse-Hinds Series EYS and EYD sealing fittings. Chico SpeedSeal restricts the passage of gases, vapors or flames through the sealing fitting and creates a seal for Class I, Division 1, Groups C, D and Class II, Division 1, Groups E, F, G hazardous areas.

Liquidtight fittings



Overview

Liquidtight fittings are used to terminate and seal liquidtight flexible metal conduit to an oiltight, raintight or liquidtight box or enclosure, where superior corrosion resistance and/or strength is required.

Available in aluminum, stainless steel, iron, zinc die cast and non-metallic.

Stainless steel fittings



Overview

Stainless steel fittings deliver unbeatable corrosion protection where you need it, saving you time and money. Superior resistance to corrosion and heat, combined with unmatched strength, make stainless steel fittings a long-term solution for even the most extreme environments.

Myers™ hubs



Overview

Myers hubs are used in the termination of electrical circuits through wall of the enclosure. Designed for use indoors or outdoors with rigid conduit and IMC. Suitable for use in environmentally demanding applications, including those with the presence of chemicals, such as acetic, citric and salt water. Also available for use in hazardous (classified) locations.

XJG conduit expansion joints for rigid/IMC



Overview

XJG expansion couplings are used with rigid metal conduit and IMC to couple together two sections of conduit subject to longitudinal movement; in conduit runs to prevent damage to conduit supports. Also used indoors or outdoors in long conduit runs to permit linear movement caused by thermal expansion and contraction and in runs that cross structural joints.

Motor control and power distribution

Clamped EBMX NEMA 7 classified enclosures

Overview

The Clamped EBMX from Eaton's Crouse-Hinds. The world's only NEMA 7 classified enclosure to utilize clamping technology.

Certifications

- Class I, Divisions 1 and 2, Groups B, C, D
- Class II, Groups E, F, G
- Class III
- Class I, Zones 1 and 2
- UL1203 Explosionproof and Dust-ignition-proof Electrical Equipment for Use in Hazardous (Classified) Locations
- cUL to CSA C22.2 No. 30
- UL/cUL certified for -50°C to +60°C
- SASO Certificate of Conformity
- NEMA 3R, 4, 4X*, 7BCD, 9EFG

Benefits

- **FASTER.** A significant reduction in installation and maintenance costs due to its revolutionary design makes opening and closing the EBMX significantly faster than traditional enclosures.
- **SAFER.** The clamps on the EBMX enclosure automatically apply even pressure across the flame path for an error-proof installation. No need to worry about missing or improperly torqued bolts creating an explosion hazard in your facility.
- The EBMX enclosure is rated Class I, Divisions 1 and 2, and has a NEMA 4 rating to protect against water ingress.

* Enclosures with PB23, RR2 and RR3 options are rated NEMA 3R. All other options maintain NEMA 4X rating.



The only clamped solution



Save time and money

- Simple clamp cover design opens in seconds
- Reduces installation and maintenance costs

Error-proof installation

- All surface clamps apply even pressure across the flame path
- No chance of missing bolts

Multi-use and highly customizable

- Designed for use as starter, combo starter, disconnect switch or breaker
- 65kAIC at 480V certified enclosure rating
- Up to 6 cover operators
- Factory wired
- Thermal magnetic and electronic trip breakers
- Bi-metallic and electronic overload starters

Patented safety

- 11 patents associated with all-clamp technology



EMN 25 and 27 pushbutton motor starters



Overview

Explosionproof, compact, across-the-line manual NEMA starter for single and polyphase VAC or VDC motors. Used for fans and blowers, pumps, compressors and conveyors.

Manual motor & line starters



Overview

NMN and GHG635 motor/line starters are used for across-the-line starting of motors, motor overload and phase failure protection and also for manual starting and stopping.

Disconnect switches



Overview

Hazardous area and ordinary location disconnect switches are used in manual "ON" and "OFF" control of single-phase or three-phase AC motors where overload protection is not required or is provided separately.

XDT hazardous area transformers



Overview

XDT hazardous location dry-type transformers are designed to operate where volatile flammable liquids or gases are handled, processed or used, and where ignitable concentrations of gases or vapors are normally prevented by positive mechanical ventilation.

Control stations



Overview

N2S and GHG43 control stations and selector switches are used for motor control, visual indication, on-off control of circuits and circuit selection.

XLPB industrial panelboards



Overview

An ideal low voltage power distribution panel for harsh and corrosive applications. Built using our high quality, field-proven Ex-CELL enclosures, the XLPB panelboard provides long product life, NEMA 4X protection and easy installation.

Available in epoxy powder coat or stainless steel.

EID explosionproof disconnect switches



Overview

EID disconnect assemblies provide an explosionproof disconnect switch assembly with small size and footprint for hazardous area electrical systems.

EIDs can be ordered as enclosure only, allowing for field installation of switch while maintaining product certification. NEMA 4X breather and drain solution in hosedown applications.

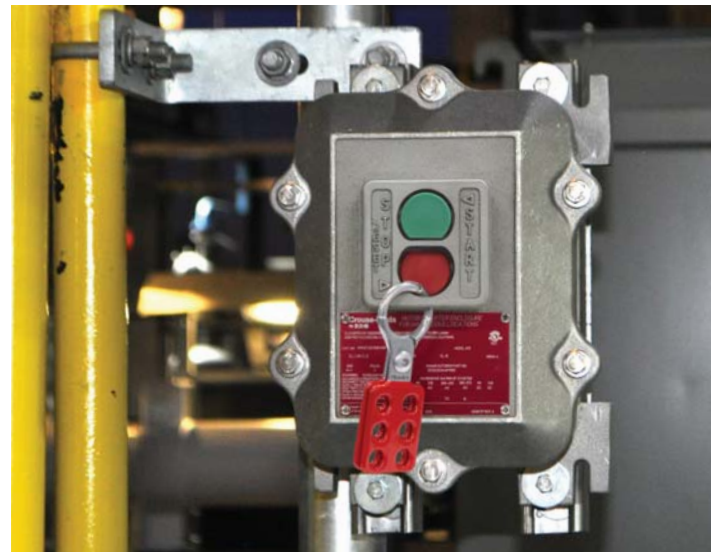

Enclosures

NEMA 4X enclosures



Overview

Broad offering of JIC, wall mount, ground mount and free-standing enclosures with superior ingress protection. Protect against corrosion, circulating and windblown dust, falling dirt, dripping non-corrosive liquids, rain, splashing water and hose-directed water.

Ex-CELL stainless steel or sheet steel enclosures



Overview

A globally certified enclosure and termination solution for Type 3S and 4X applications. Over 100 standard sizes in stainless steel and painted steel, featuring unique design features, precision manufacturing and the highest quality materials.

The premier choice for instrumentation and electrical applications across the globe.

Non-metallic enclosures for non-hazardous applications (NEMA 1, 3, 3R, 4X, 6P, 12)



Overview

Made of fiberglass-reinforced polyester, non-metallic enclosures are exceptionally durable, corrosion-resistant and can withstand abuse and exposure to chemicals, water and extreme conditions.

Extensive offering of fiberglass enclosures, including: small line, pushbutton, junction box, raised cover, Advantage, wall mount, disconnect and Xtra deep.

NEMA 7 enclosures



Overview

Explosionproof enclosures are used as a junction or pull box, enclosure for splices and branch circuit taps, terminal blocks, relays and other electrical devices.

Enclosures are certified for use in areas which are hazardous due to the presence of hydrogen or gases and vapors of equivalent hazard, such as those found in process industries.

Solar

Solar combiner boxes



Overview

Solar combiner boxes are used to group input wires/circuits from several arrays and/or solar panels. The combined circuit results in fewer output circuits and combines them into one main bus or feed going to the inverter, saving labor and material costs.

Solar recombiner boxes



Overview

Recombiner boxes are used in larger photovoltaic systems. A recombiner box effectively groups the output wires from several combiner boxes into one main output feed which then goes to the inverter.

Compact (SL) solar combiner boxes



Overview

Compact solar combiner boxes are designed and built to provide long, dependable service in a low profile, space saving design. Compact combiners are third party listed and are available in either four or six circuits, with or without fuses.

Solar cable assemblies and harnesses



Overview

Custom-configured harness assemblies are constructed using only the highest quality wire, components for durability and longevity.

Pre-made whip and jumper assemblies are ideal for speeding solar panel installation.

Structural solutions by Eaton's B-Line Division

Cable tray and accessories

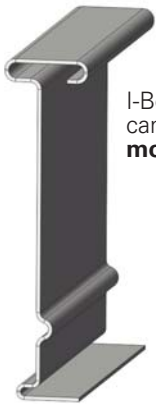

I-Beam side rail design can carry up to **2.3 times more load** than C-channel



Overview

B-Line's cable tray offering provides a strong and flexible solution for cabling/wiring throughout the rig site.

Innovative design features, such as I-Beam side rail construction, help reduce material costs, labor costs and accelerate project schedules.

Benefits

I-Beam profile

- Side rail maximizes strength to weight ratio
- Reduced hardware required on splicing saves installation costs

Application specific materials

- Aluminum, stainless steel and FA series fiberglass (electrically conductive GRP) offer increased corrosion resistance
- Hot dipped galvanized steel offers increased durability in harsh environments

Reduced support requirements

- Industry-leading 75-100mm tangents increase system strength
- Requires fewer supports than recommended by NEMA VE-2

Strut systems, fittings & accessories



Overview

4Dimension strut systems and traditional strut provide support for pipe hangers, cable tray and more. The 4Dimension strut system allows for up to 50% time and material savings on many applications.

4Dimension strut system

- Up to 50% reduction in installation time for trapeze applications
- Up to 50% reduction in material cost in many applications
- Helps save space and weight by fully utilizing multiple sides for ease and flexibility of installation
- Functional replacement for back to back strut system, with considerable cost, time and material savings
- Compatible with most traditional fittings and accessories
- Multi-side design reduces complexity of higher cost fittings required for many applications

Heavy Duty GRIP STRUT™ safety grating



Application

Eaton's B-Line series Heavy Duty Grip Strut safety grating is tailor made for slip-resistant walkways in demanding environments where mud, ice, oil and other substances can create hazardous working conditions.

Available in a wide variety of traction patterns and material types to meet your needs.

Grip Strut pattern types

No teeth

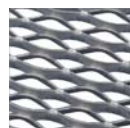

The best labor saving alternative to bar grating

Standard with teeth

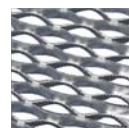

Safety, self cleaning and self draining all-in-one

Reduced opening



Limits items from falling through openings for safety below

CoSPEC

Online specification tools

Assembly PN: **VMV7L2A/UNV1**

Configuration Options

Mounting Style
Pendant Mount

Lamp
7L - (7404 Lumens)

Hub Size
3/4"

Color Temperature
5600K (cool white)

Optics
Type V

Guard
No Guard

Voltage
120-277 VAC, 50/60 Hz

Options
No Options

SELECT—Pick products you need to download to the unit level.

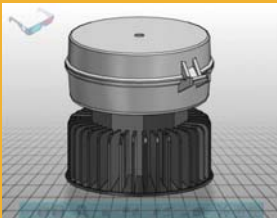

VIEW—View your chosen product in 2D or 3D.



DOWNLOAD—Output drawing and parametric data for use on your project.

CoSPEC is a suite of specification support tools that help simplify, streamline and speed up the industrial design and specification process. From lighting designs and drawing support tools to ROI calculators, submittal sheets and spec forms, CoSPEC has you covered in virtually every aspect of the design process.

3D drawing & design

The CoSpec online 3D drawing catalog gives you the ability to select and view Crouse-Hinds products in 2D and 3D formats. Then, with just a few clicks, you can download design content and parametric data in one of nearly 100 file formats. File format outputs are native to the selected software, which eliminates translation errors and speeds the integration of content into your project.

Combine this handy tool with our SKU-level submittal sheets for extra convenience.



SKU-level submittal sheets

These dynamic PDFs feature both SKU-level specification data and key family specs. The sheets also include a custom text area for unique data such as project name or fixture type, as well as an embedded 3D drawing.

Convenient resources for engineers, designers and drafters

Lighting layouts

From simple layouts to complex drawings, our lighting design engineers deliver precise, efficient, application- and environment-appropriate lighting designs. Our experts can save you time and money by creating a virtual model of a proposed design, revealing luminaire characteristics and effects within the installation.

- 3D fixture placement with access to alternate fixtures and mounting heights
- Point-by-point footcandle diagram calculations
- AutoCAD®-generated floor plan overlays
- Complete bill of material

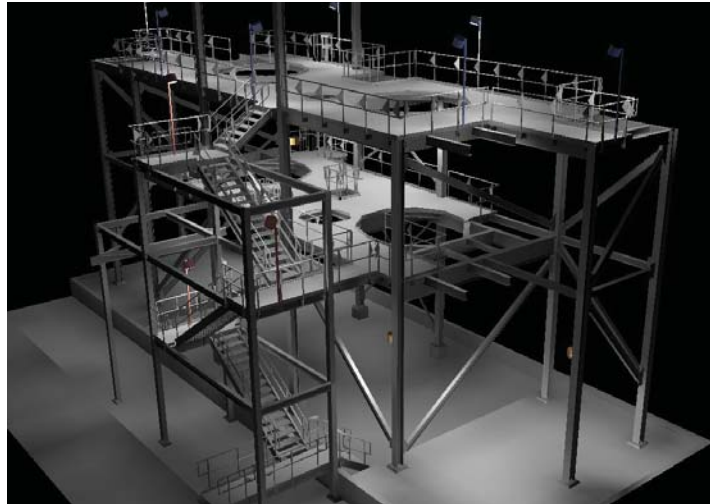

Energy Savings & Maintenance Savings			Total Cost of Ownership Comparison	
Total Cost of Ownership			Total Savings	
	400W MH	LED System		LED System
Initial investment	\$80,000.00	\$150,000.00	Energy savings	\$1,343,520.00
Utility rebate	\$0.00	(\$0.00)	Labor & material savings	\$549,818.18
Tax rebate	\$0.00	(\$0.00)	Total savings	\$1,893,338.18
Net investment	\$80,000.00	\$150,000.00	Initial Investment	(\$150,000.00)
Total energy costs	\$1,952,640.00	\$609,120.00	Estimated Utility Rebate	\$0.00
Incremental Air Cooling Energy Costs	\$0.00	\$0.00	Estimated Tax Rebate	\$0.00
Total labor costs	\$549,818.18	\$0.00	Total return	\$1,743,338.18
Total cost of ownership	\$2,582,458.18	\$759,120.00		

Payback Period on the Incremental LED Cost (years): 0.5
Payback period on the entire LED installation (years): 1.0

ROI calculators

Use our interactive online cost calculators to determine how much you or your clients will save with LED luminaires from Eaton's Crouse-Hinds. These handy, intuitive calculators allow you to enter design parameters unique to a project and view the specific savings and payback period realized.

PRODUCT SPECIFICATION GUIDE – LED LUMINAIRES – CHAMP VMV LED SERIES
SECTION 26 54 00 – CLASSIFIED LOCATION LIGHTING

Product Specification Guide – Champ® LED VMV Luminaires HI-Lumen
SECTION 26 54 00 – Classified Location Lighting

PART 1 GENERAL

1.01 SCOPE
A. Furnishing, installation, and assembly of lighting fixtures for areas classified as hazardous.

1.02 REFERENCES
A. National Fire Protection Association (NFPA):
1. NFPA 70 National Electrical Code (NEC)

Specification guide forms

Written to CSI guidelines, our specification guide forms are ideal for designers whose customers have out-of-date or incomplete spec libraries. They're a quick and easy way to optimize the safety, reliability and efficiency of your design requirements.



**U.S. (global headquarters):
Eaton's Crouse-Hinds business**

1201 Wolf Street
Syracuse, NY 13208

(866) 764-5454
FAX: (315) 477-5179
FAX Orders Only:
(866) 653-0640

crousecustomerctr@eaton.com

For more information:

If further assistance is required, please contact an authorized Eaton Distributor, Sales Office, or Customer Service Department.

Canada

Toll Free: 800-265-0502
FAX: (800) 263-9504
FAX Orders only: (866) 653-0645

Mexico/Latin America/Caribbean

52-555-804-4000
FAX: 52-555-804-4020
ventascentromex@eaton.com

Europe (Germany)

49 (0) 6271 806-500
49 (0) 6271 806-476
sales.CCH.de@cooperindustries.com

Eaton Middle East

9714-8066100
FAX: 9714-8894813
chmesales@eaton.com

Singapore

65-6645-9888
FAX: 65-6297-4819
chsi-sales@cooperindustries.com

China

86-21-2899-3600
FAX: 86-21-2899-4055
cchsales@cooperindustries.com

Korea

82-2-3484-6783
82-2-3484-6778
CCHK-sales@cooperindustries.com

Australia

61-2-8787-2777
FAX: 61-2-9609-2342
CEASales@cooperindustries.com

India

91-124-4683888
FAX: 91-124-4683899
cchindia@eaton.com

Eaton's Crouse-Hinds
1201 Wolf Street
Syracuse, NY 13208
Crouse-Hinds.com

Eaton
1000 Eaton Boulevard
Cleveland, OH 44122
United States
Eaton.com

© 2016 Eaton
All Rights Reserved
Printed in USA
Publication No. 5277-0216
February 2016

Eaton is a registered trademark.
All other trademarks are property of their respective owners.